



中国认可  
国际互认  
检测  
TESTING  
CNAS L3163

# CE&UKCA EMC Test Report

**Project No.** : 2403C177A  
**Equipment** : 1) 30W USB-C Wall Charger  
2) 35W USB-C Wall Charger  
**Brand Name** : Suparo  
**Model Name** : 1) S30B, S30W, S30  
2) P1135BUK  
**Applicant** : Suparo Industries Ltd  
**Address** : Weir Street, Blackburn, BB2 2AN, United Kingdom  
**Manufacturer** : Foshan G-power Technology Co.,Ltd  
**Address** : B4-601, 602, 603, 604, 702, 704,SXC, No.1 Fusheng West Rd, Dafuji  
Comm, Ronggui Str, Shunde Dist, Foshan City, Guangdong P.R.,China  
**Factory** : Foshan G-power Technology Co.,Ltd  
**Address** : B4-601, 602, 603, 604, 702, 704,SXC, No.1 Fusheng West Rd, Dafuji  
Comm, Ronggui Str, Shunde Dist, Foshan City, Guangdong P.R.,China  
**Date of Receipt** : Mar. 26, 2024  
**Date of Test** : Mar. 27, 2024 ~ May 30, 2024  
**Issued Date** : Dec. 10, 2024  
**Report Version** : R00  
**Test Sample** : Engineering Sample No.: SSL2024032639  
**Standard(s)** : EN 55032:2015+A11:2020  
EN IEC 61000-3-2:2019+A1:2021  
EN 61000-3-3:2013+A2:2021  
EN 55035:2017+A11:2020  
  
BS EN 55032:2015+A11:2020  
BS EN IEC 61000-3-2:2019+A1:2021  
BS EN 61000-3-3:2013+A2:2021  
BS EN 55035:2017+A11:2020

The above equipment has been tested and found compliance with the requirement of the relative standards by BTL Inc.(Dongguan).

**Prepared by** : Wade Liang  
Wade Liang

**Approved by** : Kevin Li  
Kevin Li

1-2/F., 4/F., Building A, 1-2/F. of Building B, 3/F. of Building C, No.3, Jinshagang 1st Road,  
Dalang, Dongguan, Guangdong, China

Tel: +86-769-8318-3000 Web: www.newbtl.com Service mail: btl\_qa@newbtl.com

**Declaration**

**BTL** represents to the client that testing is done in accordance with standard procedures as applicable and that test instruments used has been calibrated with standards traceable to international standard(s) and/or national standard(s).

**BTL's** reports apply only to the specific samples tested under conditions. It is manufacture's responsibility to ensure that additional production units of this model are manufactured with the identical electrical and mechanical components. **BTL** assumes no responsibility for the data provided by the customer, any statements, inferences or generalizations drawn by the customer or others from the reports issued by **BTL**. The report must not be used by the client to claim product certification, approval, or endorsement by **CNAS**. This report is the confidential property of the client. As a mutual protection to the clients, the public and ourselves, the test report shall not be reproduced, except in full, without our written approval.

**BTL's** laboratory quality assurance procedures are in compliance with the **ISO/IEC 17025: 2017** requirements, and accredited by the conformity assessment authorities listed in this test report.

**BTL** is not responsible for the sampling stage, so the results only apply to the sample as received.

The information, data and test plan are provided by manufacturer which may affect the validity of results, so it is manufacturer's responsibility to ensure that the apparatus meets the essential requirements of applied standards and in all the possible configurations as representative of its intended use.

**Limitation**

For the use of the authority's logo is limited unless the Test Standard(s)/Scope(s)/Item(s) mentioned in this test report is (are) included in the conformity assessment authorities acceptance respective.

Please note that the measurement uncertainty is provided for informational purpose only and are not use in determining the Pass/Fail results.

<b>Table of Contents</b>		<b>Page</b>
<b>REPORT ISSUED HISTORY</b>		<b>6</b>
<b>1 . SUMMARY OF TEST RESULTS</b>		<b>7</b>
1.1 TEST FACILITY		8
1.2 MEASUREMENT UNCERTAINTY		8
1.3 TEST ENVIRONMENT CONDITIONS		10
<b>2 . GENERAL INFORMATION</b>		<b>11</b>
2.1 GENERAL DESCRIPTION OF EUT		11
2.2 DESCRIPTION OF TEST MODES		12
2.3 EUT OPERATING CONDITIONS		13
2.4 BLOCK DIAGRAM SHOWING THE CONFIGURATION OF SYSTEM TESTED		13
2.5 DESCRIPTION OF SUPPORT UNITS		13
<b>3 . EMC EMISSION TEST</b>		<b>14</b>
3.1 RADIATED EMISSIONS UP TO 1 GHZ		14
3.1.1 LIMITS		14
3.1.2 MEASUREMENT INSTRUMENTS LIST		14
3.1.3 TEST PROCEDURE		15
3.1.4 DEVIATION FROM TEST STANDARD		15
3.1.5 TEST SETUP		15
3.1.6 MEASUREMENT DISTANCE		16
3.1.7 TEST RESULTS		17
3.2 CONDUCTED EMISSION MEASUREMENT AT AC MAINS POWER PORTS		21
3.2.1 LIMITS		21
3.2.2 MEASUREMENT INSTRUMENTS LIST		21
3.2.3 TEST PROCEDURE		22
3.2.4 DEVIATION FROM TEST STANDARD		22
3.2.5 TEST SETUP		22
3.2.6 TEST RESULTS		23
3.3 HARMONIC CURRENT EMISSIONS TEST		27
3.3.1 LIMITS		27
3.3.2 MEASUREMENT INSTRUMENTS LIST		27
3.3.3 TEST PROCEDURE		27
3.3.4 DEVIATION FROM TEST STANDARD		27
3.3.5 TEST SETUP		27
3.3.6 TEST RESULTS		28
3.4 VOLTAGE FLUCTUATIONS (FLICKER) TEST		31
3.4.1 LIMITS		31
3.4.2 MEASUREMENT INSTRUMENTS LIST		31
3.4.3 TEST PROCEDURE		31

<b>Table of Contents</b>		<b>Page</b>
3.4.4 DEVIATION FROM TEST STANDARD		31
3.4.5 TEST SETUP		31
3.4.6 TEST RESULTS		32
<b>4 . EMC IMMUNITY TEST</b>		<b>33</b>
4.1 STANDARD COMPLIANCE/SEVERITY LEVEL/CRITERIA		33
4.2 GENERAL PERFORMANCE CRITERIA		36
4.3 ELECTROSTATIC DISCHARGE IMMUNITY TEST (ESD)		37
4.3.1 TEST SPECIFICATION		37
4.3.2 MEASUREMENT INSTRUMENTS		37
4.3.3 TEST PROCEDURE		37
4.3.4 DEVIATION FROM TEST STANDARD		38
4.3.5 TEST SETUP		38
4.3.6 TEST RESULTS		39
4.4 RADIATED, RADIO-FREQUENCY, ELECTROMAGNETIC FIELD IMMUNITY TEST (RS)		41
4.4.1 TEST SPECIFICATION		41
4.4.2 MEASUREMENT INSTRUMENTS		41
4.4.3 TEST PROCEDURE		41
4.4.4 DEVIATION FROM TEST STANDARD		42
4.4.5 TEST SETUP		42
4.4.6 TEST RESULTS		43
4.5 ELECTRICAL FAST TRANSIENT/BURST IMMUNITY TEST (EFT)		44
4.5.1 TEST SPECIFICATION		44
4.5.2 MEASUREMENT INSTRUMENTS		44
4.5.3 TEST PROCEDURE		44
4.5.4 DEVIATION FROM TEST STANDARD		44
4.5.5 TEST SETUP		45
4.5.6 TEST RESULTS		46
4.6 SURGE IMMUNITY TEST (SURGE)		47
4.6.1 TEST SPECIFICATION		47
4.6.2 MEASUREMENT INSTRUMENTS		47
4.6.3 TEST PROCEDURE		47
4.6.4 DEVIATION FROM TEST STANDARD		47
4.6.5 TEST SETUP		48
4.6.6 TEST RESULTS		49
4.7 IMMUNITY TO CONDUCTED DISTURBANCES, INDUCED BY RADIO-FREQUENCY		
FIELDS TEST (CS)		50
4.7.1 TEST SPECIFICATION		50
4.7.2 MEASUREMENT INSTRUMENTS		50
4.7.3 TEST PROCEDURE		50
4.7.4 DEVIATION FROM TEST STANDARD		50
4.7.5 TEST SETUP		51
4.7.6 TEST RESULTS		52

<b>Table of Contents</b>		<b>Page</b>
<b>4.8 POWER FREQUENCY MAGNETIC FIELD IMMUNITY TEST (PFMF)</b>		<b>53</b>
<b>4.8.1 TEST SPECIFICATION</b>		<b>53</b>
<b>4.8.2 MEASUREMENT INSTRUMENTS</b>		<b>53</b>
<b>4.8.3 TEST PROCEDURE</b>		<b>53</b>
<b>4.8.4 DEVIATION FROM TEST STANDARD</b>		<b>53</b>
<b>4.8.5 TEST SETUP</b>		<b>54</b>
<b>4.8.6 TEST RESULTS</b>		<b>55</b>
<b>4.9 VOLTAGE DIPS, SHORT INTERRUPTIONS AND VOLTAGE VARIATIONS IMMUNITY TEST (DIPS)</b>		<b>56</b>
<b>4.9.1 TEST SPECIFICATION</b>		<b>56</b>
<b>4.9.2 MEASUREMENT INSTRUMENTS</b>		<b>56</b>
<b>4.9.3 TEST PROCEDURE</b>		<b>56</b>
<b>4.9.4 DEVIATION FROM TEST STANDARD</b>		<b>56</b>
<b>4.9.5 TEST SETUP</b>		<b>57</b>
<b>4.9.6 TEST RESULTS</b>		<b>58</b>
<b>5 . EUT TEST PHOTO</b>		<b>59</b>

**REPORT ISSUED HISTORY**

Report No.	Version	Description	Issued Date	Note
BTL-EMC-1-2403C177A	R00	This is a copy report which referencing test data are provided from test report (BTL-EMC-1-2403C177). 1. The product name, series model, brand name and applicant information have changed. 2. Added the UK standards. These changes do not affect the test results. The rest are kept the same.	Dec. 10, 2024	Valid

## 1. SUMMARY OF TEST RESULTS

Test procedures according to the technical standards:

Emission			
Standard(s)	Test Item		Result
EN 55032:2015+A11:2020 BS EN 55032:2015+A11:2020	Radiated emissions up to 1 GHz		PASS
	Radiated emissions above 1 GHz		N/A
	Radiated emissions from FM receivers		N/A
	Conducted emissions AC mains power port		PASS
	Asymmetric mode conducted emissions	AAN	N/A
		Current Probe	N/A
		CP+CVP	N/A
Conducted differential voltage emissions		N/A	

Standard(s)	Test Item	Result
EN IEC 61000-3-2:2019+A1:2021 BS EN IEC 61000-3-2:2019+A1:2021	Harmonic current	PASS
EN 61000-3-3:2013+A2:2021 BS EN 61000-3-3:2013+A2:2021	Voltage fluctuations (Flicker)	PASS

Immunity			
Standard(s)	Ref Standard(s)	Test Item	Result
EN 55035:2017+A11:2020 BS EN 55035:2017+A11:2020	IEC 61000-4-2:2008	ESD	PASS
	IEC 61000-4-3:2020	RS	PASS
	IEC 61000-4-4:2012	EFT	PASS
	IEC 61000-4-5:2014+AMD1:2017	Surge	PASS
	IEC 61000-4-6:2013	CS	PASS
	IEC 61000-4-8:2009	PFMF	PASS
	IEC 61000-4-11:2020	Dips	PASS

Standard(s)	Section	Test Item	Result
EN 55035:2017+A11:2020 BS EN 55035:2017+A11:2020	4.2.7	BIN-R	N/A
	4.2.7	BIN-I	N/A

NOTE:

- (1) "N/A" denotes test is not applicable to this device.

## 1.1 TEST FACILITY

The test facilities used to collect the test data in this report is at the location of Room 108-116, 309-310, Building 2, No.1, Yile Road, Songshan Lake Zone, Dongguan, Guangdong, China.

## 1.2 MEASUREMENT UNCERTAINTY

Where relevant, the following measurement uncertainty levels have been estimated for tests performed on the EUT as specified in CISPR 16-4-2, The BTL measurement uncertainty is less than the CISPR 16-4-2  $U_{\text{cispr}}$  requirement.

The reported uncertainty of measurement  $y \pm U$ , where expanded uncertainty  $U$  is based on a standard uncertainty multiplied by a coverage factor of  $k=2$ , providing a level of confidence of approximately **95%**.

A. Radiated emissions up to 1 GHz measurement:

Test Site	Method	Measurement Frequency Range	Ant. H / V	$U$ ,(dB)
SSL-CB01 (3m)	CISPR	30MHz ~ 200MHz	V	4.70
		30MHz ~ 200MHz	H	3.56
		200MHz ~ 1,000MHz	V	4.92
		200MHz ~ 1,000MHz	H	4.54

B. Conducted emissions AC mains power port measurement:

Test Site	Method	Measurement Frequency Range	$U$ ,(dB)
SSL-C01	CISPR	150kHz ~ 30MHz	2.68

C. Harmonic current / Voltage fluctuations (Flicker) measurement:

Test Site	Method	Item	$U$ (%)
SSL-C01	EN IEC 61000-3-2 EN 61000-3-3	Voltage	0.817
		Current	0.817

## D. Immunity Measurement:

Test Site	Method	Item	U
SSL-SR02	IEC 61000-4-2	Rise time tr	6.7%
		Peak current Ip	6.5%
		Current at 30 ns	6.4%
		Current at 60 ns	6.4%
SSL-CB03	IEC 61000-4-3 (80MHz~6GHz)	Electromagnetic field immunity test	2.26dB
SSL-SR01	IEC 61000-4-4	Peak voltage (VP)	3.7%
		Rise time (tr)	4.4%
		Pulse width(tw)	4.2%
		Pulse Freq.(kHz)	0.7%
		Burst Duration(ms)	1.4%
		Burst Period(ms)	1.4%
SSL-SR01	IEC 61000-4-5	Open-Circuit Output Voltage (1.2/50us)	4.0%
		Open circuit front time (1.2/50us)	6.1%
		Open circuit time of half value (1.2/50us)	4.7%
SSL-CB02	IEC 61000-4-6 (150kHz-80MHz)	CDN	1.28dB
SSL-SR01	IEC 61000-4-8	Magnetic Field Strength	1.91%
SSL-SR01	IEC 61000-4-11	DIP Amplitude	3.6%

Note: Unless specifically mentioned, the uncertainty of measurement has not been taken into account to declare the compliance or non-compliance to the specification.

### 1.3 TEST ENVIRONMENT CONDITIONS

Test Item	Temperature	Humidity	Tested By	Tested Date
Radiated emissions up to 1 GHz	22°C	51%	Geoffrey Zou	May 14, 2024
Conducted emissions AC mains power port	24°C	45%	Harry Tan	Mar. 29, 2024
Harmonic current	24°C	45%	Atom Huang	Apr. 01, 2024
Voltage fluctuations (Flicker)	24°C	45%	Atom Huang	Apr. 01, 2024

Test Item	Temperature	Humidity	Pressure	Tested By	Tested Date
ESD	23°C	40%	1014hPa	Atom Huang	Mar. 29, 2024
RS	24°C	55%	/	Niko Zhao	Mar. 29, 2024
EFT	20°C	56%	/	Leonard Li	May 20, 2024
Surge	20°C	56%	/	Leonard Li	May 20, 2024
CS	23°C	52%	/	Sam Li	Mar. 29, 2024
PFMF	20°C	56%	/	Leonard Li	May 20, 2024
Dips	20°C	56%	/	Leonard Li	May 20, 2024

## 2. GENERAL INFORMATION

### 2.1 GENERAL DESCRIPTION OF EUT

Equipment	1) 30W USB-C Wall Charger 2) 35W USB-C Wall Charger
Brand Name	Suparo
Model Name	1) S30B, S30W, S30 2) P1135BUK
Test Model	P1135BUK
Model Difference(s)	All models are the same except for model name and output ratings.
Identification No. of EUT(S/N)	N/A
Dimensions and mass	48.4*31.5*31.5mm
Component unit of EUT	<input checked="" type="checkbox"/> Single unit <input type="checkbox"/> Multiple unit
Sample Status	<input checked="" type="checkbox"/> Engineering sample <input type="checkbox"/> Final shipment prototype
Power Source	AC Mains.
Power Rating	Model P1135BUK: I/P: 100-240V ~ 50/60Hz 1.2A O/P: 5.0Vdc, 3.0A; 9.0Vdc, 3.0A; 12.0Vdc, 2.91A; 15.0Vdc, 2.33A; 20.0Vdc, 1.75A; PPS: 5-11.0Vdc, 3.0A (Max 35W) Model S30B, S30W, S30: I/P: 100-240V ~ 50/60Hz 1.0A O/P: 5.0Vdc, 3.0A; 9.0Vdc, 3.0A; 12.0Vdc, 2.5A; 15.0Vdc, 2.0A; 20.0Vdc, 1.5A; PPS: 5-11.0Vdc, 3.0A (Max 30W)
Connecting I/O Port(s)	1*Type-C Port
Classification of EUT	Class B
Highest Internal Frequency(Fx)	100KHz

Note:

- For a more detailed features description, please refer to the manufacturer's specifications or the user's manual.

Model	Output Rating	Plug type	With LED or no
S30B, S30W, S30	30W Max.	British plug	with
P1135BUK	35W Max.	British plug	with

## 2.2 DESCRIPTION OF TEST MODES

To investigate the maximum EMI emission characteristics generated from EUT, the test system was pre-scanning tested based on the consideration of following EUT operation mode or test configuration mode which possible have effect on EMI emission level. Each of these EUT operation mode(s) or test configuration mode(s) mentioned above was evaluated respectively.

Pretest Mode	Description
Mode 1	FULL LOAD ( 20V/1.75A )

Radiated emissions up to 1 GHz Test	
Final Test Mode	Description
Mode 1	FULL LOAD ( 20V/1.75A )

Conducted emissions AC mains power port Test	
Final Test Mode	Description
Mode 1	FULL LOAD ( 20V/1.75A )

Harmonic current & Voltage fluctuations (Flicker) Test	
Final Test Mode	Description
Mode 1	FULL LOAD ( 20V/1.75A )

Immunity Test	
Final Test Mode	Description
Mode 1	FULL LOAD ( 20V/1.75A )

**Note:**

1. Test samples with different powers, consistent appearance and interior, with internal software control for power output. So only tested the Power 35W (model: P1135BUK).

### 2.3 EUT OPERATING CONDITIONS

The EUT exercise program used during radiated and/or conducted emission measurement was designed to exercise the various system components in a manner similar to a typical use. The standard test signals and output signal as following:

1. EUT connected LOAD via Type-C Cable.

### 2.4 BLOCK DIAGRAM SHOWING THE CONFIGURATION OF SYSTEM TESTED

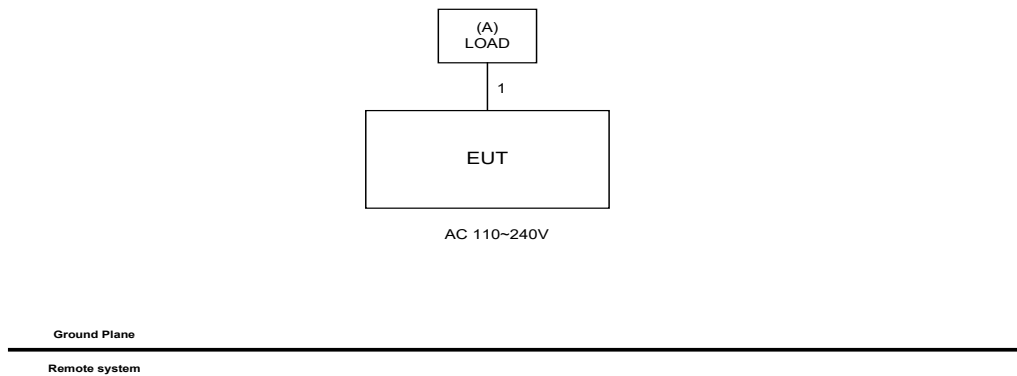

### 2.5 DESCRIPTION OF SUPPORT UNITS

The EUT has been tested as an independent unit together with other necessary accessories or support units. The following support units or accessories were used to form a representative test configuration during the tests.

Item	Equipment	Mfr/Brand	Model/Type No.	Series No.
A	LOAD	N/A	N/A	N/A

Item	Cable Type	Shielded Type	Ferrite Core	Length
1	Type-C Cable	YES	NO	1.2m

### 3. EMC EMISSION TEST

#### 3.1 RADIATED EMISSIONS UP TO 1 GHZ

##### 3.1.1 LIMITS

Class B equipment up to 1 GHz

Frequency Range MHz	Measurement			Class B limits dB(μV/m)
	Facility	Distance m	Detector type/ bandwidth	
30 - 230	SAC	3	Quasi peak / 120 kHz	40
230 - 1000				47

Notes:

- (1) The limit for radiated test was performed according to as following: EN 55032
- (2) The tighter limit applies at the band edges.
- (3) Emission level (dBuV/m)=20log Emission level (uV/m).
- (4) The test result calculated as following:  
 Measurement Value = Reading Level + Correct Factor  
 Correct Factor = Antenna Factor + Cable Loss - Amplifier Gain(if use)  
 Margin Level = Measurement Value - Limit Value

Required highest frequency for radiated measurement

Highest internal frequency ( $F_x$ )	Highest measured frequency
$F_x \leq 108$ MHz	1 GHz
$108 < F_x \leq 500$ MHz	2 GHz
$500 < F_x \leq 1000$ MHz	5 GHz
$F_x > 1$ GHz	5 x $F_x$ up to a maximum of 6 GHz

##### 3.1.2 MEASUREMENT INSTRUMENTS LIST

Item	Kind of Equipment	Manufacturer	Type No.	Serial No.	Calibrated until
1	Trilog-Broadband Antenna	Schwarzbeck	VULB9168	01587	Apr. 25, 2025
2	Attenuator	EMCI	VFA_Z04002-N-06	N/A	Apr. 25, 2025
3	MXE EMI Receiver	Keysight	N9038A	MY59050118	Sep. 26, 2024
4	Preamplifier	EMC INSTRUMENT	EMC001330	980825	Jan. 19, 2025
5	Cable	EMC INSTRUMENT	EMCCFD400-N M-NM-2500	N/A	Jun. 08, 2024
6	Cable	EMC INSTRUMENT	EMCCFD400-N M-NM-7000	N/A	Jun. 08, 2024
7	Cable	EMC INSTRUMENT	EMCCFD400-N M-NM-3000	N/A	Jun. 08, 2024
8	Measurement Software	Farad	EZ-EMC Ver.NB-03A1-01	N/A	N/A

Remark: "N/A" denotes no model name, no serial no. or no calibration specified.

All calibration period of equipment list is one year.

**3.1.3 TEST PROCEDURE**

- a. The measuring distance of 3 m shall be used for measurements. The EUT was placed on the top of a rotating table 0.8 meter above the ground at a 3 meter semi-anechoic chamber. The table was rotated 360 degrees to determine the position of the highest radiation.
- b. The height of the equipment or of the substitution antenna shall be 0.8 m, the height of the test antenna shall vary between 1 m to 4 m. Both horizontal and vertical polarizations of the antenna are set to make the measurement.
- c. The initial step in collecting radiated emission data is a receiver peak detector mode pre-scanning the measurement frequency range. Significant peaks are then marked and then Quasi Peak detector mode re-measured.
- d. All readings are Peak unless otherwise stated QP in column of Note. Peak denotes that the Peak reading compliance with the QP Limits and then QP Mode measurement didn't perform.
- e. For the actual test configuration, please refer to the related Item - EUT Test Photos.

**3.1.4 DEVIATION FROM TEST STANDARD**

No deviation

**3.1.5 TEST SETUP**

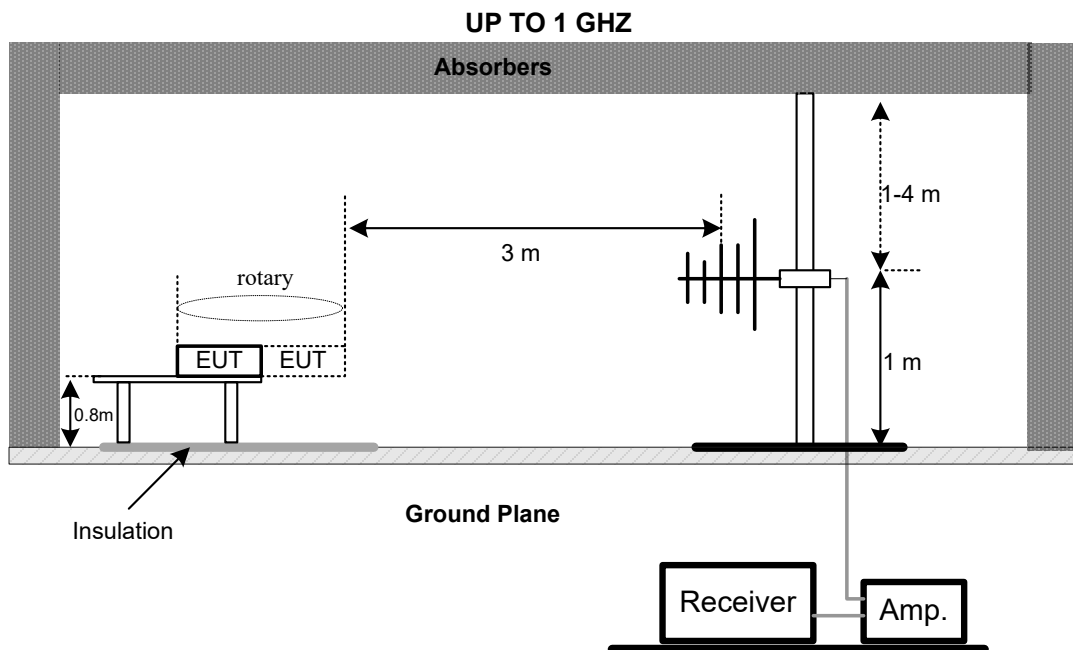

### 3.1.6 MEASUREMENT DISTANCE

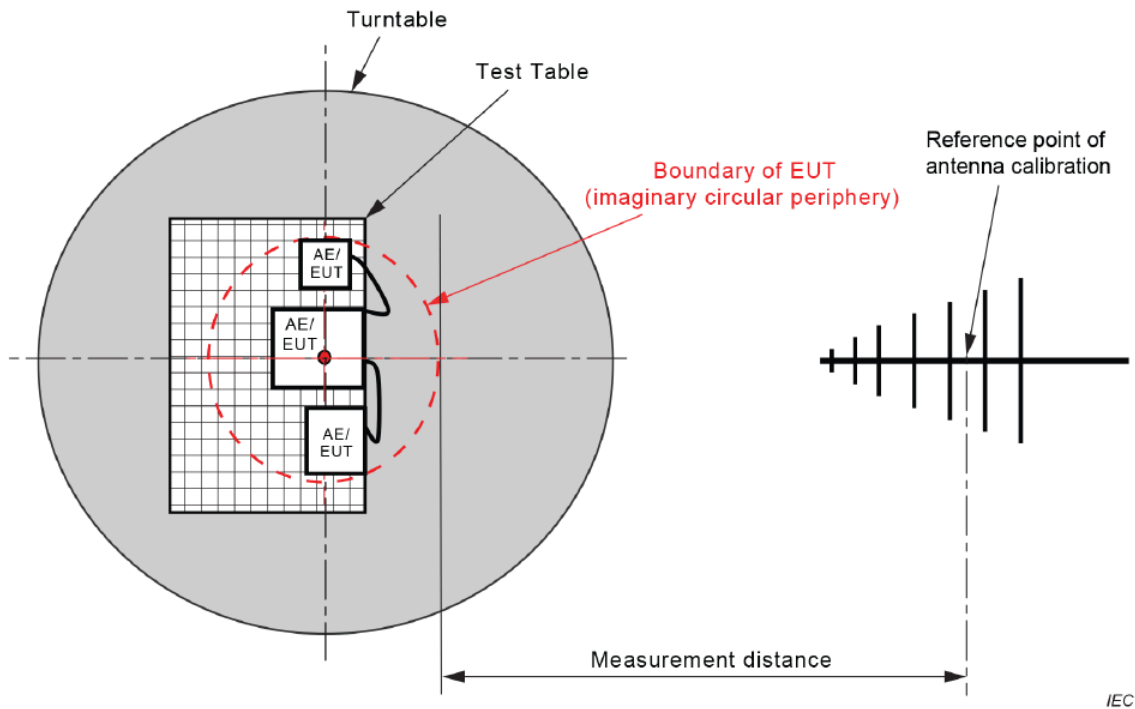

Figure C.1 – Measurement distance

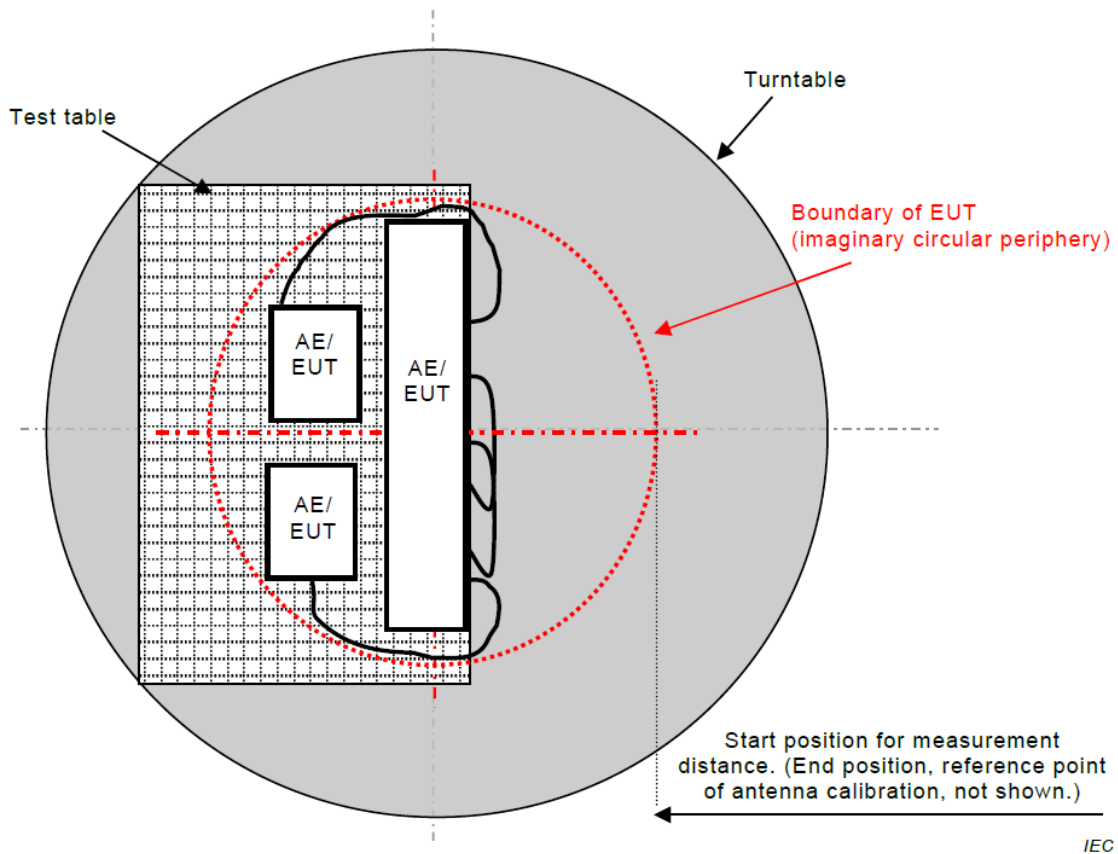
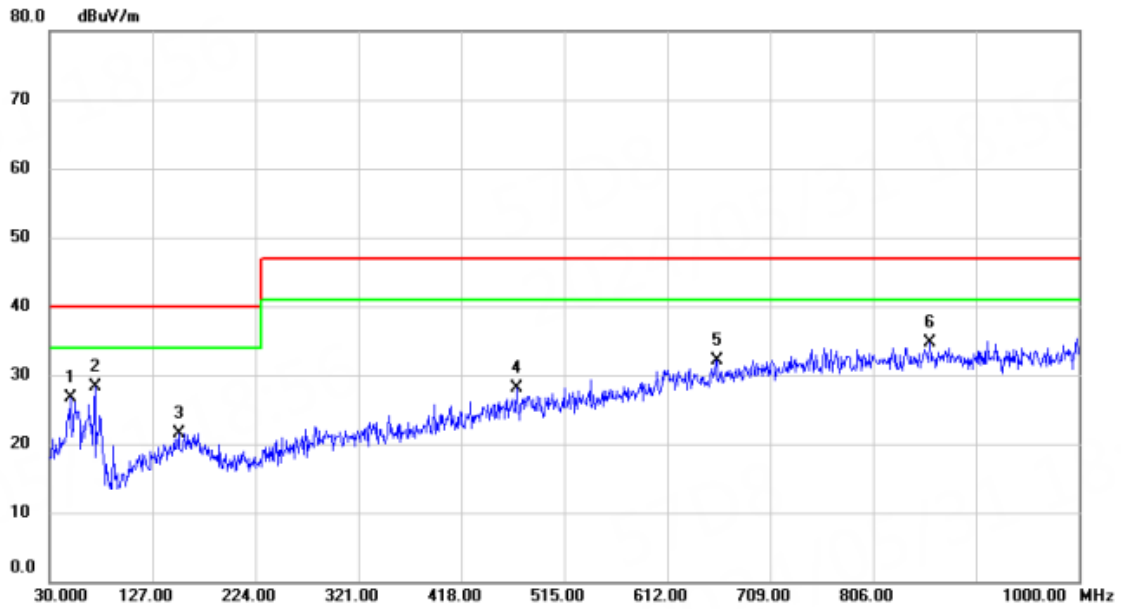

Figure C.2 – Boundary of EUT, Local AE and associated cabling

### 3.1.7 TEST RESULTS

Test Voltage	AC 230V/50Hz	Polarization	Vertical
Test Mode	Mode 1		



No.	Mk.	Freq. MHz	Reading Level dBuV	Correct Factor dB	Measure- ment dBuV/m	Limit dBuV/m	Margin dB	Detector	Comment
1		49.8850	38.52	-11.89	26.63	40.00	-13.37	QP	
2	*	72.6800	42.74	-14.50	28.24	40.00	-11.76	QP	
3		151.7350	33.21	-11.66	21.55	40.00	-18.45	QP	
4		469.8950	34.96	-6.95	28.01	47.00	-18.99	QP	
5		658.5600	35.39	-3.20	32.19	47.00	-14.81	QP	
6		859.3500	34.88	-0.17	34.71	47.00	-12.29	QP	

Test Voltage	AC 230V/50Hz	Polarization	Horizontal
Test Mode	Mode 1		

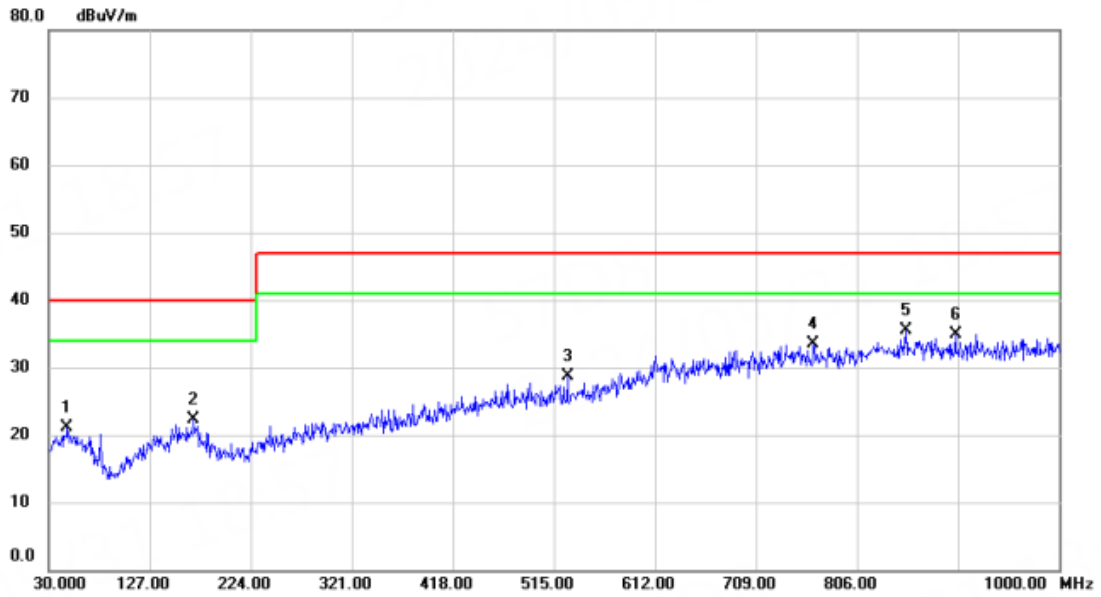

No. Mk.	Freq. MHz	Reading Level dBuV	Correct Factor dB	Measurement dBuV/m	Limit dBuV/m	Margin dB	Detector	Comment
1	47.9450	33.05	-11.93	21.12	40.00	-18.88	QP	
2	168.7100	34.29	-12.05	22.24	40.00	-17.76	QP	
3	528.0950	34.80	-6.05	28.75	47.00	-18.25	QP	
4	764.2900	34.89	-1.44	33.45	47.00	-13.55	QP	
5 *	852.5600	35.69	-0.18	35.51	47.00	-11.49	QP	
6	900.5750	35.01	-0.12	34.89	47.00	-12.11	QP	

Test Voltage	AC 110V/60Hz	Polarization	Vertical
Test Mode	Mode 1		

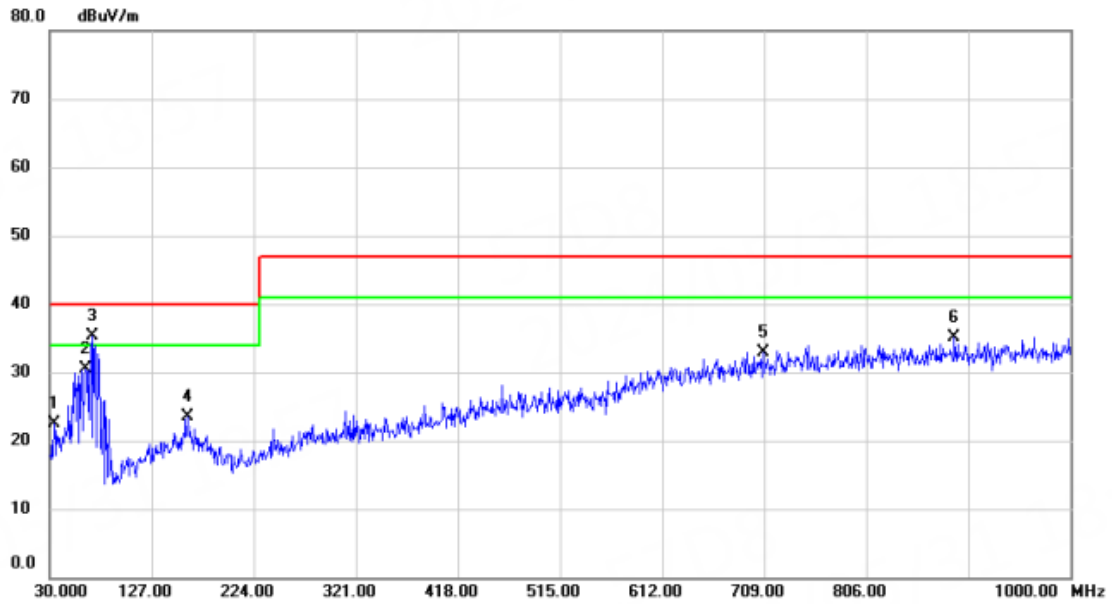

No.	Mk.	Freq. MHz	Reading Level dBuV	Correct Factor dB	Measure- ment dBuV/m	Limit dBuV/m	Margin dB	Detector	Comment
1		34.3650	35.26	-12.81	22.45	40.00	-17.55	QP	
2		64.4350	43.43	-12.97	30.46	40.00	-9.54	QP	
3	*	70.2550	49.35	-13.96	35.39	40.00	-4.61	QP	
4		161.4350	35.17	-11.63	23.54	40.00	-16.46	QP	
5		708.0300	35.02	-2.10	32.92	47.00	-14.08	QP	
6		889.4200	35.30	-0.13	35.17	47.00	-11.83	QP	

Test Voltage	AC 110V/60Hz	Polarization	Horizontal
Test Mode	Mode 1		

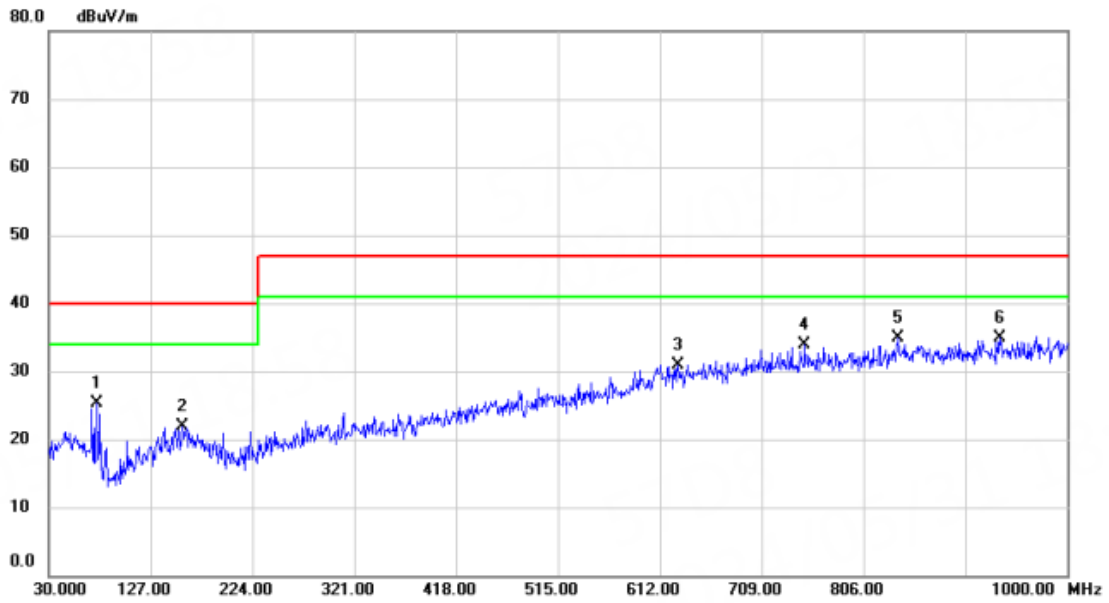

No.	Mk.	Freq. MHz	Reading Level dBuV	Correct Factor dB	Measure- ment dBuV/m	Limit dBuV/m	Margin dB	Detector	Comment
1		75.5900	40.49	-15.18	25.31	40.00	-14.69	QP	
2		157.5550	33.49	-11.57	21.92	40.00	-18.08	QP	
3		629.4600	34.51	-3.54	30.97	47.00	-16.03	QP	
4		749.7400	35.38	-1.52	33.86	47.00	-13.14	QP	
5	*	839.4650	35.33	-0.40	34.93	47.00	-12.07	QP	
6		936.4650	34.75	0.13	34.88	47.00	-12.12	QP	

### 3.2 CONDUCTED EMISSION MEASUREMENT AT AC MAINS POWER PORTS

#### 3.2.1 LIMITS

Requirements for conducted emissions from AC mains power ports of Class B equipment

Frequency Range MHz	Coupling Device	Detector Type / bandwidth	Class B Limits (dB(μV))
0.15 - 0.5	AMN	Quasi Peak / 9 kHz	66-56
0.5 - 5			56
5 - 30			60
0.15 - 0.5	AMN	Average / 9 kHz	56-46
0.5 - 5			46
5 - 30			50

**NOTE:**

(1) The test result calculated as following:

Measurement Value = Reading Level + Correct Factor

Correct Factor = Insertion Loss + Cable Loss + Attenuator Factor(if use)

Margin Level = Measurement Value – Limit Value

#### 3.2.2 MEASUREMENT INSTRUMENTS LIST

Item	Kind of Equipment	Manufacturer	Type No.	Serial No.	Calibrated until
1	TWO-LINE V-NETWORK	R&S	ENV216	102771	Sep. 25, 2024
2	EMI Test Receiver	R&S	ESCI	100895	Jan. 19, 2025
3	Cable	N/A	RG400	N/A	Mar. 05, 2025
4	Measurement Software	Farad	EZ-EMC Ver.NB-03A1-01	N/A	N/A

Remark: "N/A" denotes no model name, no serial no. or no calibration specified.

All calibration period of equipment list is one year.

### 3.2.3 TEST PROCEDURE

- a. The EUT was placed 0.8 meters from the horizontal ground plane with EUT being connected to the power mains through a line impedance stabilization network (LISN). All other support equipment powered from additional LISN(s). The LISN provide 50 Ohm/ 50uH of coupling impedance for the measuring instrument.
- b. Interconnecting cables that hang closer than 40 cm to the ground plane shall be folded back and forth in the center forming a bundle 30 to 40 cm long.
- c. I/O cables that are not connected to a peripheral shall be bundled in the center. The end of the cable may be terminated, if required, using the correct terminating impedance. The overall length shall not exceed 1 m.
- d. LISN at least 80 cm from nearest part of EUT chassis.
- e. For the actual test configuration, please refer to the related Item –EUT Test Photos.

### 3.2.4 DEVIATION FROM TEST STANDARD

No deviation

### 3.2.5 TEST SETUP

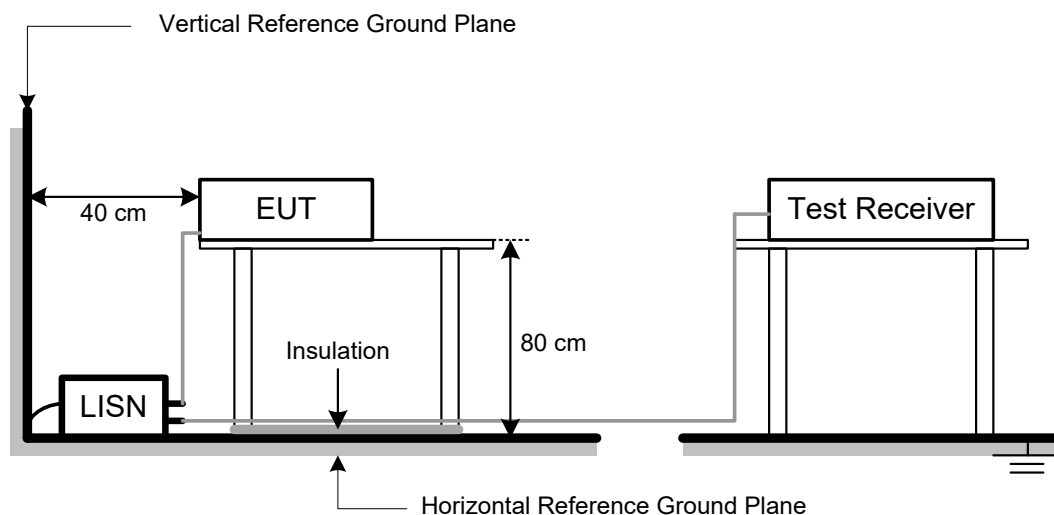

### 3.2.6 TEST RESULTS

Test Voltage	AC 230V/50Hz	Phase	Line
Test Mode	Mode 1		

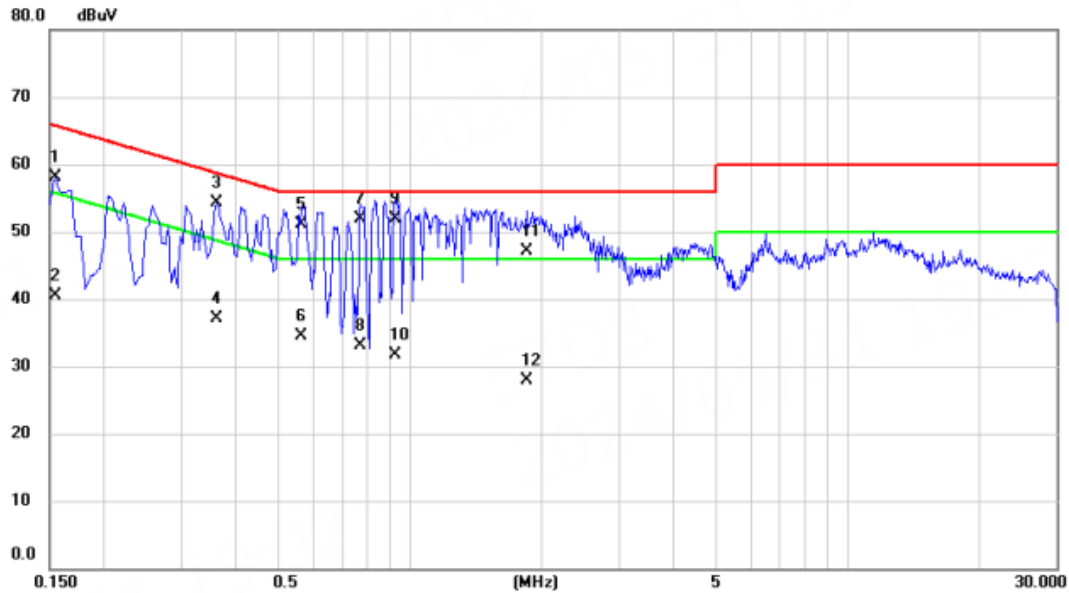

No.	Mk.	Freq. MHz	Reading Level dBuV	Correct Factor dB	Measure- ment dBuV	Limit dBuV	Margin dB	Detector	Comment
1		0.1545	48.26	9.92	58.18	65.75	-7.57	QP	
2		0.1545	30.50	9.92	40.42	55.75	-15.33	AVG	
3		0.3615	44.34	9.96	54.30	58.69	-4.39	QP	
4		0.3615	27.10	9.96	37.06	48.69	-11.63	AVG	
5		0.5640	41.10	10.01	51.11	56.00	-4.89	QP	
6		0.5640	24.40	10.01	34.41	46.00	-11.59	AVG	
7		0.7710	41.80	10.05	51.85	56.00	-4.15	QP	
8		0.7710	23.10	10.05	33.15	46.00	-12.85	AVG	
9	*	0.9240	41.90	10.07	51.97	56.00	-4.03	QP	
10		0.9240	21.70	10.07	31.77	46.00	-14.23	AVG	
11		1.8465	36.90	10.19	47.09	56.00	-8.91	QP	
12		1.8465	17.70	10.19	27.89	46.00	-18.11	AVG	

Test Voltage	AC 230V/50Hz	Phase	Neutral
Test Mode	Mode 1		

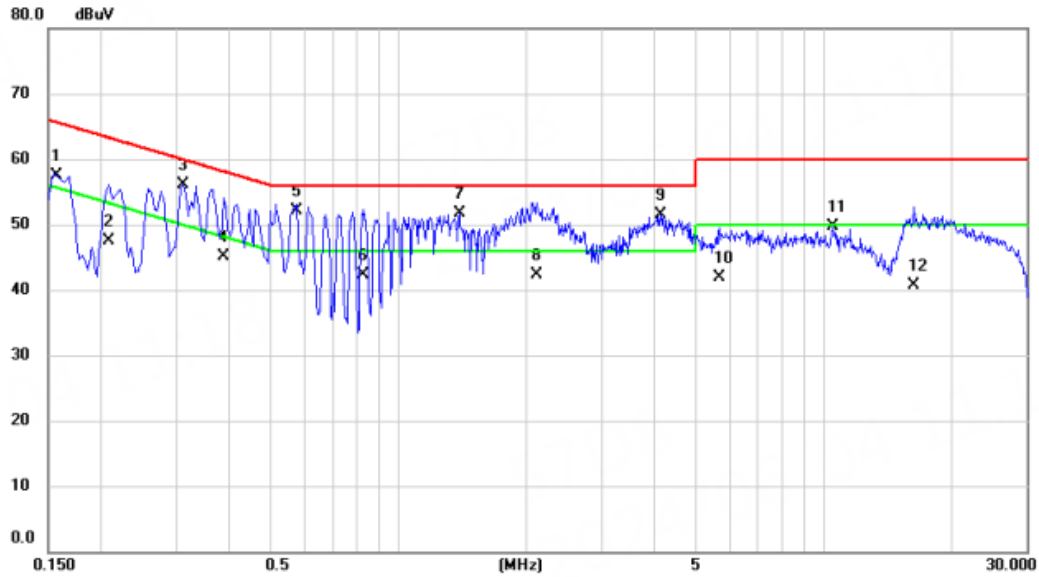

No. Mk.	Freq. MHz	Reading Level dBuV	Correct Factor dB	Measure- ment dBuV	Limit dBuV	Margin dB	Detector	Comment
1	0.1572	47.52	9.93	57.45	65.61	-8.16	QP	
2	0.2084	37.52	9.94	47.46	53.27	-5.81	AVG	
3	0.3120	46.10	9.97	56.07	59.92	-3.85	QP	
4 *	0.3885	35.10	9.99	45.09	48.10	-3.01	AVG	
5	0.5774	42.11	10.02	52.13	56.00	-3.87	QP	
6	0.8250	32.29	10.07	42.36	46.00	-3.64	AVG	
7	1.3920	41.48	10.14	51.62	56.00	-4.38	QP	
8	2.1120	32.04	10.25	42.29	46.00	-3.71	AVG	
9	4.1280	40.80	10.64	51.44	56.00	-4.56	QP	
10	5.6894	30.81	11.02	41.83	50.00	-8.17	AVG	
11	10.5270	37.45	12.25	49.70	60.00	-10.30	QP	
12	16.2285	27.45	13.20	40.65	50.00	-9.35	AVG	

Test Voltage	AC 110V/60Hz	Phase	Line
Test Mode	Mode 1		

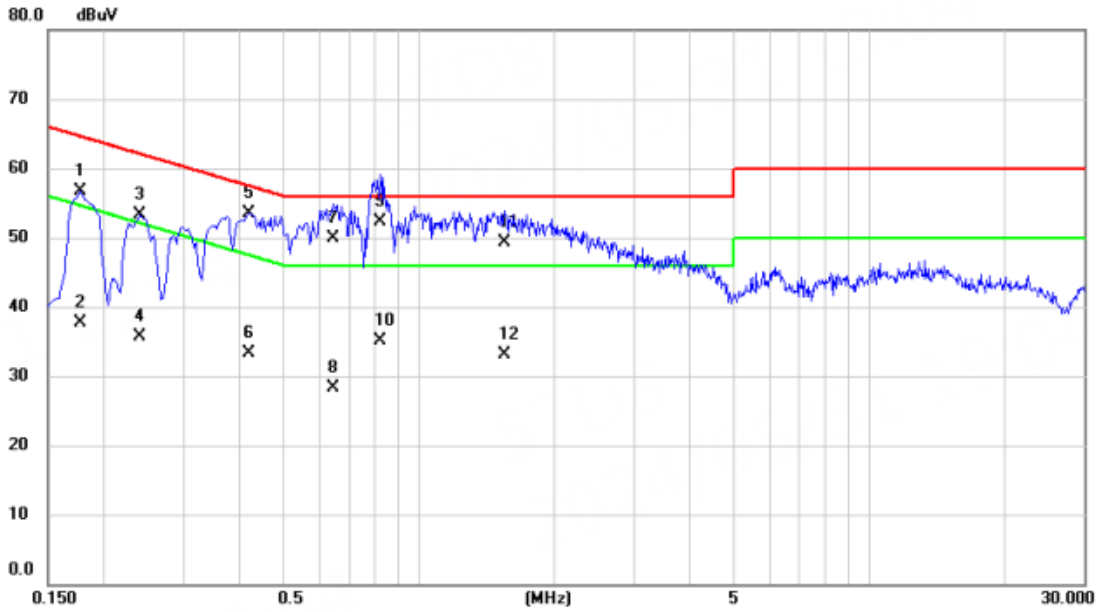

No. Mk.	Freq. MHz	Reading Level dBuV	Correct Factor dB	Measure- ment dBuV	Limit dBuV	Margin dB	Detector	Comment
1	0.1770	46.72	9.94	56.66	64.63	-7.97	QP	
2	0.1770	27.80	9.94	37.74	54.63	-16.89	AVG	
3	0.2400	43.29	9.95	53.24	62.10	-8.86	QP	
4	0.2400	25.70	9.95	35.65	52.10	-16.45	AVG	
5	0.4200	43.50	9.98	53.48	57.45	-3.97	QP	
6	0.4200	23.40	9.98	33.38	47.45	-14.07	AVG	
7	0.6450	39.90	10.02	49.92	56.00	-6.08	QP	
8	0.6450	18.30	10.02	28.32	46.00	-17.68	AVG	
9 *	0.8205	42.20	10.05	52.25	56.00	-3.75	QP	
10	0.8205	25.10	10.05	35.15	46.00	-10.85	AVG	
11	1.5494	39.20	10.15	49.35	56.00	-6.65	QP	
12	1.5494	23.00	10.15	33.15	46.00	-12.85	AVG	

Test Voltage	AC 110V/60Hz	Phase	Neutral
Test Mode	Mode 1		

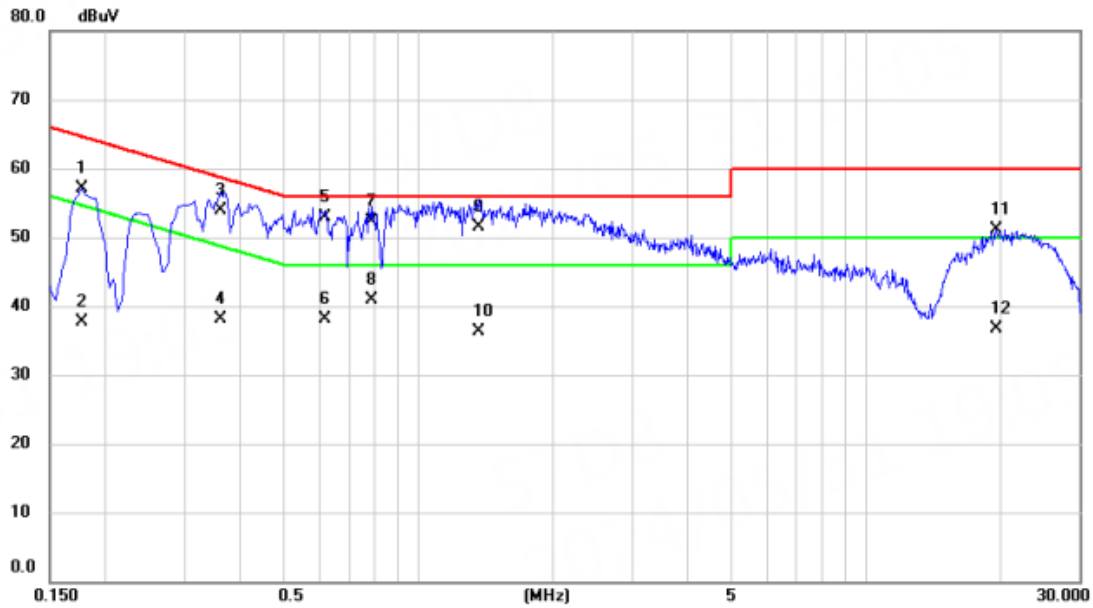

No.	Mk.	Freq. MHz	Reading Level dBuV	Correct Factor dB	Measure- ment dBuV	Limit dBuV	Margin dB	Detector	Comment
1		0.1770	47.18	9.93	57.11	64.63	-7.52	QP	
2		0.1770	27.70	9.93	37.63	54.63	-17.00	AVG	
3		0.3615	43.90	9.98	53.88	58.69	-4.81	QP	
4		0.3615	28.10	9.98	38.08	48.69	-10.61	AVG	
5	*	0.6180	42.79	10.03	52.82	56.00	-3.18	QP	
6		0.6180	28.10	10.03	38.13	46.00	-7.87	AVG	
7		0.7890	42.16	10.07	52.23	56.00	-3.77	QP	
8		0.7890	30.80	10.07	40.87	46.00	-5.13	AVG	
9		1.3605	41.30	10.14	51.44	56.00	-4.56	QP	
10		1.3605	26.20	10.14	36.34	46.00	-9.66	AVG	
11		19.5450	37.45	13.70	51.15	60.00	-8.85	QP	
12		19.5450	23.10	13.70	36.80	50.00	-13.20	AVG	

### 3.3 HARMONIC CURRENT EMISSIONS TEST

#### 3.3.1 LIMITS

The power consumption is less than 75W, there is no limit applied.

#### 3.3.2 MEASUREMENT INSTRUMENTS LIST

Item	Kind of Equipment	Manufacturer	Type No.	Serial No.	Calibrated until
1	Harmonic current/voltage wave analyzer	EMC Partner	HAR1000-1P230V	103488-0270	Sep. 21, 2024
2	Measurement Software	EMC-PARTNER	Harmonics-1000	N/A	N/A

Remark: "N/A" denotes no model name, no serial No. or no calibration specified.  
All calibration period of equipment list is one year.

#### 3.3.3 TEST PROCEDURE

- The EUT was placed on the top of a wooden table 0.8 meters above the ground and operated to produce the maximum harmonic components under normal operating conditions.
- The classification of EUT is according to of EN IEC 61000-3-2. The EUT is classified as Class A.
- The correspondent test program of test instrument to measure the current harmonics emanated from EUT is chosen. The measure time shall be not less than the time necessary for the EUT to be exercised.

#### 3.3.4 DEVIATION FROM TEST STANDARD

No deviation

#### 3.3.5 TEST SETUP

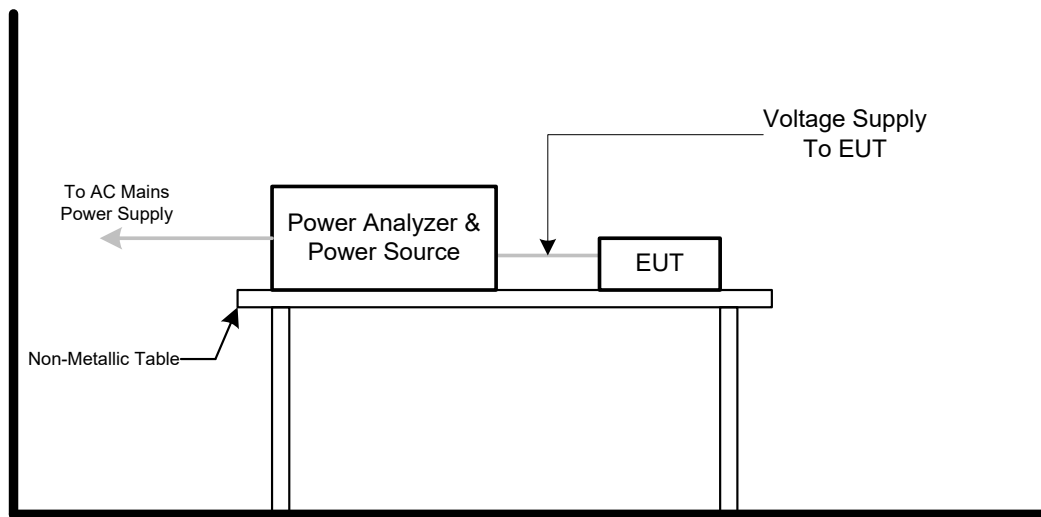

### 3.3.6 TEST RESULTS

Harmonics – Class-A	
Test Voltage	AC 230V/50Hz
Test Mode	Mode 1

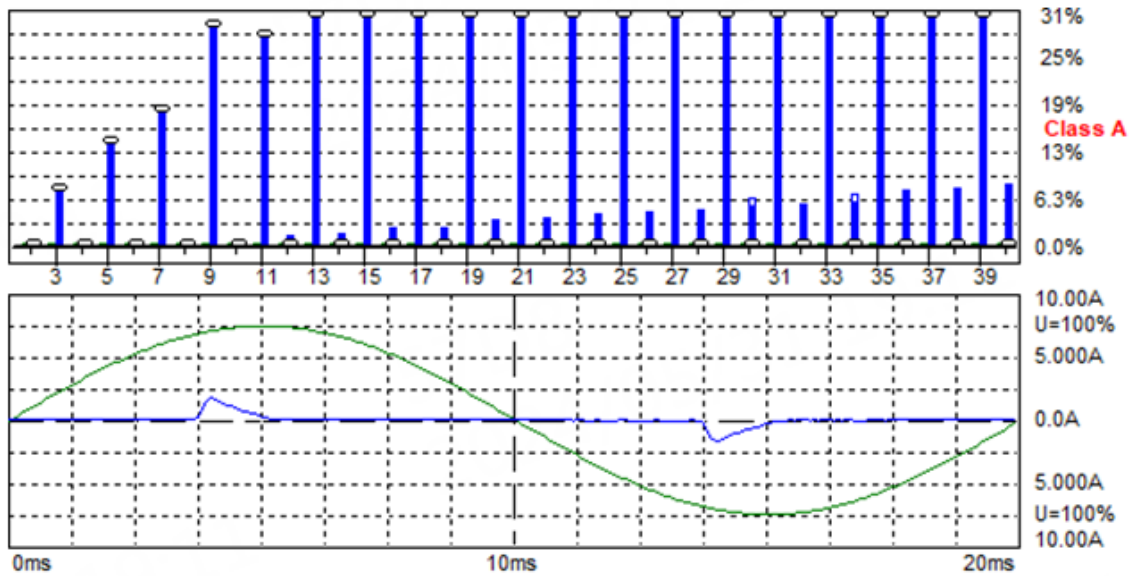

Harmonic Emission - IEC 61000-3-2 , EN 61000-3-2 , (EN60555-2)

2024/4/1 16:37:56

Urms = 230.3 V    P = 41.23 W    THC = 0.347 A  
 Irms = 0.381 A    pf = 0.470

Range: 10 A  
 V-nom: 230 V  
 TestTime: 3 min (100%)

**Test completed, Result: PASSED**

HAR-1000 EMC-Partner

## Current Test Result Summary (Run time)

Test Voltage	AC 230V/50Hz
Test Mode	Mode 1

Urms = 230.3V Freq = 49.974 Range: 10 A  
 Irms = 0.381A Ipk = 1.807A cf = 4.744  
 P = 41.23W S = 87.71VA pf = 0.470  
 THDi = 188 % THDu = 0.10 % Class A

Test - Time : 3min ( 100 %)

Test completed, Result: PASSED

Order	Freq. [Hz]	Iavg [A]	Irms [A]	I <sub>max</sub> [A]	Limit [A]	Status	Vrms [V]	V <sub>max</sub> [V]	Limit [V]
1	50	0.1830	0.1843	0.1855			230.18	230.18	0.0000
2	100	0.0000	0.0000	0.0000	1.0800		0.1963	0.2454	0.4663
3	150	0.1711	0.1721	0.1727	2.3000		0.0736	0.0982	2.0615
4	200	0.0000	0.0006	0.0006	0.4300		0.0491	0.0736	0.4663
5	250	0.1574	0.1581	0.1587	1.1400		0.0491	0.0491	0.9081
6	300	0.0000	0.0012	0.0012	0.3000		0.0245	0.0491	0.4663
7	350	0.1388	0.1398	0.1398	0.7700		0.0491	0.0491	0.6872
8	400	0.0000	0.0012	0.0012	0.2300		0.0245	0.0245	0.4663
9	450	0.1161	0.1166	0.1166	0.4000		0.0491	0.0491	0.4663
10	500	0.0000	0.0012	0.0012	0.1840		0.0245	0.0245	0.4663
11	550	0.0922	0.0934	0.0934	0.3300		0.0245	0.0245	0.2209
12	600	0.0000	0.0018	0.0018	0.1533		0.0245	0.0245	0.2209
13	650	0.0720	0.0726	0.0726	0.2100		0.0491	0.0491	0.2209
14	700	0.0000	0.0018	0.0018	0.1314		0.0000	0.0245	0.2209
15	750	0.0566	0.0574	0.0574	0.1500		0.0245	0.0491	0.2209
16	800	0.0000	0.0024	0.0024	0.1150		0.0000	0.0245	0.2209
17	850	0.0467	0.0476	0.0476	0.1324		0.0245	0.0245	0.2209
18	900	0.0000	0.0024	0.0024	0.1022		0.0000	0.0245	0.2209
19	950	0.0438	0.0446	0.0446	0.1184		0.0245	0.0245	0.2209
20	1000	0.0000	0.0031	0.0031	0.0920		0.0000	0.0245	0.2209
21	1050	0.0429	0.0439	0.0439	0.1071		0.0245	0.0245	0.2209
22	1100	0.0000	0.0031	0.0031	0.0836		0.0000	0.0245	0.2209
23	1150	0.0417	0.0427	0.0427	0.0978		0.0245	0.0491	0.2209
24	1200	0.0000	0.0031	0.0031	0.0767		0.0000	0.0245	0.2209
25	1250	0.0389	0.0403	0.0403	0.0900		0.0245	0.0245	0.2209
26	1300	0.0000	0.0031	0.0031	0.0708		0.0245	0.0245	0.2209
27	1350	0.0348	0.0360	0.0360	0.0833		0.0245	0.0245	0.2209
28	1400	0.0000	0.0031	0.0031	0.0657		0.0000	0.0000	0.2209
29	1450	0.0306	0.0317	0.0317	0.0776		0.0245	0.0245	0.2209
30	1500	0.0000	0.0031	0.0037	0.0613		0.0000	0.0245	0.2209
31	1550	0.0268	0.0281	0.0281	0.0726		0.0245	0.0245	0.2209
32	1600	0.0000	0.0031	0.0031	0.0575		0.0000	0.0245	0.2209
33	1650	0.0245	0.0256	0.0256	0.0682		0.0245	0.0245	0.2209
34	1700	0.0000	0.0031	0.0037	0.0541		0.0000	0.0245	0.2209
35	1750	0.0233	0.0244	0.0244	0.0643		0.0245	0.0245	0.2209
36	1800	0.0000	0.0037	0.0037	0.0511		0.0245	0.0245	0.2209
37	1850	0.0223	0.0232	0.0232	0.0608		0.0245	0.0245	0.2209
38	1900	0.0000	0.0037	0.0037	0.0484		0.0000	0.0245	0.2209
39	1950	0.0214	0.0226	0.0226	0.0577		0.0245	0.0245	0.2209
40	2000	0.0000	0.0037	0.0037	0.0460		0.0245	0.0245	0.2209

Voltage Source Verification Data (Run time)	
Test Voltage	AC 230V/50Hz
Test Mode	Mode 1

Order	Limits in Ampere			
	90%	100%	150%	200%
2	0.9717	1.0797	1.6196	2.1594
3	2.0698	2.2998	3.4497	4.5996
4	0.3873	0.4303	0.6454	0.8606
5	1.0261	1.1401	1.7102	2.2803
6	0.2703	0.3003	0.4504	0.6006
7	0.6932	0.7703	1.1554	1.5405
8	0.2071	0.2301	0.3452	0.4602
9	0.3598	0.3998	0.5997	0.7996
10	0.1653	0.1837	0.2756	0.3674
11	0.2972	0.3302	0.4953	0.6604
12	0.1379	0.1532	0.2298	0.3064
13	0.1890	0.2100	0.3149	0.4199
14	0.1181	0.1312	0.1968	0.2625
15	0.1351	0.1501	0.2252	0.3003
16	0.1033	0.1147	0.1721	0.2295
17	0.1192	0.1324	0.1987	0.2649
18	0.0917	0.1019	0.1529	0.2039
19	0.1066	0.1184	0.1776	0.2368
20	0.0829	0.0922	0.1382	0.1843
21 *	0.0967	0.1074	0.1611	0.2148
22	0.0753	0.0836	0.1254	0.1672
23 *	0.0879	0.0977	0.1465	0.1953
24	0.0692	0.0769	0.1154	0.1538
25 *	0.0807	0.0897	0.1346	0.1794
26	0.0637	0.0708	0.1062	0.1416
27 *	0.0753	0.0836	0.1254	0.1672
28	0.0593	0.0659	0.0989	0.1318
29 *	0.0698	0.0775	0.1163	0.1550
30	0.0549	0.0610	0.0916	0.1221
31 *	0.0654	0.0726	0.1089	0.1453
32	0.0516	0.0574	0.0861	0.1147
33 *	0.0615	0.0684	0.1025	0.1367
34	0.0489	0.0543	0.0815	0.1086
35 *	0.0577	0.0641	0.0961	0.1282
36	0.0461	0.0513	0.0769	0.1025
37 *	0.0549	0.0610	0.0916	0.1221
38	0.0434	0.0482	0.0723	0.0964
39 *	0.0522	0.0580	0.0870	0.1160
40	0.0412	0.0458	0.0687	0.0916

### 3.4 VOLTAGE FLUCTUATIONS (FLICKER) TEST

#### 3.4.1 LIMITS

Tests	Limits	Descriptions
	EN 61000-3-3	
Pst	$\leq 1.0$ , Tp= 10 min.	Short Term Flicker Indicator
Plt	$\leq 0.65$ , Tp=2 hr.	Long Term Flicker Indicator
dc	$\leq 3.3\%$	Relative Steady-State V-Change
dmax	$\leq 4\%$	Maximum Relative V-change
d (t)	$\leq 500$ ms	Relative V-change characteristic

#### 3.4.2 MEASUREMENT INSTRUMENTS LIST

Item	Kind of Equipment	Manufacturer	Type No.	Serial No.	Calibrated until
1	Harmonic current/voltage wave analyzer	EMC Partner	HAR1000-1P230V	103488-0270	Sep. 21, 2024
2	Measurement Software	EMC-PARTNER	Harmonics-1000	N/A	N/A

Remark: "N/A" denotes no model name, no serial No. or no calibration specified.  
All calibration period of equipment list is one year.

#### 3.4.3 TEST PROCEDURE

- Tests was performed according to the Test Conditions/Assessment of Voltage Fluctuations specified in EN 61000-3-3 depend on which standard adopted for compliance measurement.
- All types of harmonic current and/or voltage fluctuation in this report are assessed by direct measurement using flicker-meter.

#### 3.4.4 DEVIATION FROM TEST STANDARD

No deviation

#### 3.4.5 TEST SETUP

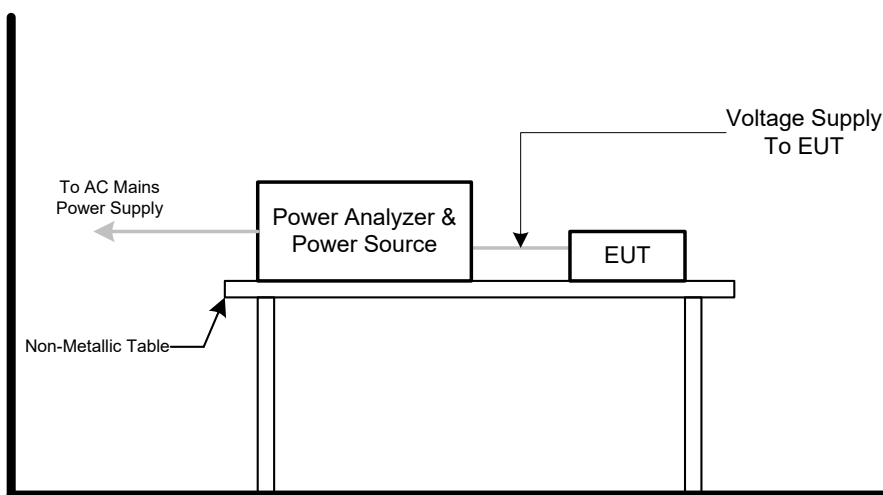

### 3.4.6 TEST RESULTS

Test Voltage	AC 230V/50Hz
Test Mode	Mode 1

Flicker Emission IEC 61000-4-15 for 230V/50Hz

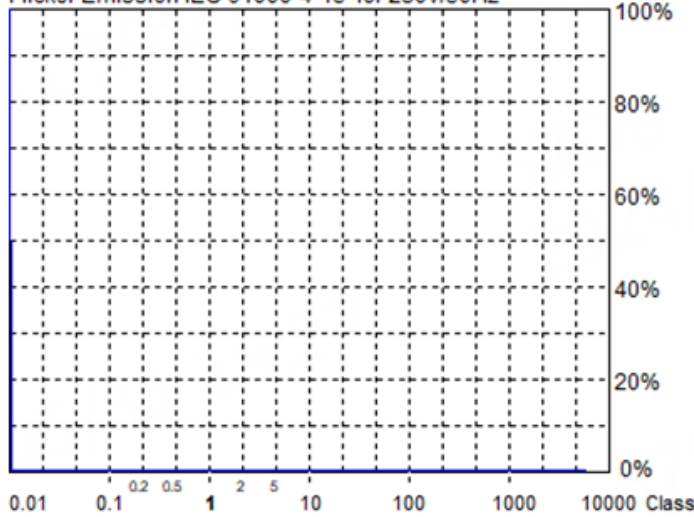

**Actual Flicker (Fli):** 0.00  
**Short-term Flicker (Pst):** 0.07  
 Limit (Pst): 1.00  
**Long-term Flicker (Plt):** 0.07  
 Limit (Plt): 0.65  
**Maximum Relative Volt. Change (dmax):** 0.00%  
 Limit (dmax): 4.00%  
**Relative Steady-state Voltage Change (dc):** 0.02%  
 Limit (dc): 3.30%  
**Tmax 3.00% (dt):** 0.00ms  
 Limit (dt>Lim): 500ms

Flicker Emission - IEC 61000-3-3 , EN 61000-3-3

Urms = 230.1 V P = 40.99 W  
 Irms = 0.430 A pf = 0.415

2024/4/1 16:49:59

Range: 10 A  
 V-nom: 230 V  
 TestTime: 10 min (100%)

**Test completed, Result: PASSED**

HAR-1000 EMC-Partner

Urms = 230.1V Freq = 49.987 Range: 10 A  
 Irms = 0.430A Ipk = 2.036A cf = 4.739  
 P = 40.99W S = 98.87VA pf = 0.415

Test - Time : 1 x 10min = 10min ( 100 %)

LIN (Line Impedance Network) : L: 0.24ohm +j0.15ohm N: 0.16ohm +j0.10ohm

Limits : Plt : 0.65 Pst : 1.00  
 dmax : 4.00 % dc : 3.30 %  
 dtLim: 3.00 % dt>Lim: 500ms

Test completed, Result: PASSED

	Pst	P3s	Fli	dmax [%]
1	0.072	0.010	0.000	0.000

#### 4. EMC IMMUNITY TEST

##### 4.1 STANDARD COMPLIANCE/SEVERITY LEVEL/CRITERIA

Tests Standard No.	Test Specification Level / Test Mode	Test Ports	Criteria
Electrostatic discharge IEC 61000-4-2 (ESD)	±8kV air discharge ±4kV contact discharge (Direct Mode)	Enclosure	B
	±4kV HCP discharge ±4kV VCP discharge (Indirect Mode)	Enclosure	B
Continuous RF electromagnetic field disturbances,swept test IEC 61000-4-3 (RS)	80 MHz to 1000 MHz 3V/m(unmodulated, r.m.s), 1 kHz, 80%, AM modulated	Enclosure	A
Continuous RF electromagnetic field disturbances,spot test IEC 61000-4-3 (RS)	1800 MHz, 2600MHz, 3500 MHz, 5000MHz(±1 %) 3V/m(unmodulated, r.m.s), 1 kHz, 80%, AM modulated	Enclosure	A
Electrical fast transient/burst immunity IEC 61000-4-4 (EFT)	±0.5kV(peak) 5/50ns Tr/Th 5kHz Repetition Frequency (100kHz Repetition Frequency for xDSL port)	Analogue/digital data ports <b>(NOTE 2)</b>	B
	±0.5kV(peak) 5/50ns Tr/Th 5kHz Repetition Frequency	DC network power ports <b>(NOTE 2)</b>	B
	±1 kV(peak) 5/50ns Tr/Th 5kHz Repetition Frequency	AC mains power ports	B

Surge immunity IEC 61000-4-5 (Surge)	<b>Port Type: unshielded symmetrical</b>		
	<b>Apply: lines to ground</b>		
	<b>Primary protection is Intended</b> ±1 kV and ±4 kV 10/700(5/320)Tr/Th µs	Analogue/digital data ports <b>(NOTE 1) &amp; (NOTE 2)</b>	C
	<b>Primary protection is not Intended</b> ±1 kV 10/700(5/320) Tr/Th µs		C
	<b>Port type: coaxial or shielded</b>		
	<b>Apply: shield to ground</b>		
±0.5 kV 1.2/50(8/20) Tr/Th µs	Analogue/digital data ports <b>(NOTE 1) &amp; (NOTE 2)</b>	B	
<b>line to reference ground for each individual line:</b> ±0.5 kV(peak) 1.2/50(8/20) Tr/Th µs	DC network power ports <b>(NOTE 2)</b>	B	
±1 kV(peak) 1.2/50(8/20) Tr/Th µs (line to line) ±2 kV(peak) 1.2/50(8/20) Tr/Th µs (line to earth or ground)	AC mains power ports	B	
Continuous induced RF disturbances IEC 61000-4-6 (CS)	0.15 MHz to 10 MHz 3V(unmodulated, r.m.s), 10 MHz to 30 MHz 3V to 1V(unmodulated, r.m.s), 30 MHz to 80 MHz 1V(unmodulated, r.m.s), 1kHz 80%, AM 150Ω source impedance	Analogue/digital data ports <b>(NOTE 2)</b>	A
	0.15 MHz to 10 MHz 3V(unmodulated, r.m.s), 10 MHz to 30 MHz 3V to 1V(unmodulated, r.m.s), 30 MHz to 80 MHz 1V(unmodulated, r.m.s), 1kHz 80%, AM 150Ω source impedance	DC network power ports <b>(NOTE 2)</b>	A
	0.15 MHz to 10 MHz 3V(unmodulated, r.m.s), 10 MHz to 30 MHz 3V to 1V(unmodulated, r.m.s), 30 MHz to 80 MHz 1V(unmodulated, r.m.s), 1kHz 80%, AM 150Ω source impedance	AC mains power ports	A

Power frequency magnetic field immunity IEC 61000-4-8 (PFMF)	50 Hz or 60Hz, 1A/m(r.m.s)	Enclosure	A
Voltage dips, short interruptions and voltage variations immunity IEC 61000-4-11 (Dips)	Voltage dips: Residual voltage<5% 0.5 cycle Residual voltage<70% 25 cycle(50Hz), 30 cycle (60Hz) Voltage interruptions: Residual voltage<5% 250 cycle (50Hz), 300 cycle (60Hz)	AC Power Ports	B C C
Broadband impulse noise disturbances, repetitive (BIN-R)	0.15 MHz to 0.5 MHz 107 dBuV 0.5 MHz to 10 MHz 107 dBuV to 36 dBuV 10 MHz to 30 MHz 36 dBuV to 30 dBuV	Analogue/digital data ports <b>(Applicable only to CPE xDSL ports)</b>	A
	0.70 ms 8.3 ms(for 60Hz) 10 ms(for 50Hz)	Analogue/digital data ports <b>(Apply period based on the AC mains frequency)</b>	A
Broadband impulse noise disturbances, isolated (BIN-I)	0.15 MHz to 30 MHz 110 dBuV	Analogue/digital data ports <b>(Applicable only to CPE xDSL ports)</b>	B
	0.24 ms 10 ms 300 ms	Analogue/digital data ports <b>(Apply all burst durations)</b>	B

**Note.**

- 1) Applicable only to ports which, according to the manufacturer's specification, may connect directly to outdoor cables.
- 2) Applicable only to ports which, according to the manufacturer's specification, support cable lengths greater than 3 m.

## 4.2 GENERAL PERFORMANCE CRITERIA

According to **EN 55035** standards, the general performance criteria as following:

<p><b>Criterion A</b></p>	<p>The equipment shall continue to operate as intended without operator intervention. No degradation of performance, loss of function or change of operating state is allowed below a performance level specified by the manufacturer when the equipment is used as intended. The performance level may be replaced by a permissible loss of performance. If the minimum performance level or the permissible performance loss is not specified by the manufacturer, then either of these may be derived from the product description and documentation, and by what the user may reasonably expect from the equipment if used as intended.</p>
<p><b>Criterion B</b></p>	<p>During the application of the disturbance, degradation of performance is allowed. However, no unintended change of actual operating state or stored data is allowed to persist after the test. After the test, the equipment shall continue to operate as intended without operator intervention; no degradation of performance or loss of function is allowed, below a performance level specified by the manufacturer, when the equipment is used as intended. The performance level may be replaced by a permissible loss of performance. If the minimum performance level (or the permissible performance loss), or recovery time, is not specified by the manufacturer, then either of these may be derived from the product description and documentation, and by what the user may reasonably expect from the equipment if used as intended.</p>
<p><b>Criterion C</b></p>	<p>Loss of function is allowed, provided the function is self-recoverable, or can be restored by the operation of the controls by the user in accordance with the manufacturer's instructions. A reboot or re-start operation is allowed. Information stored in non-volatile memory, or protected by a battery backup, shall not be lost.</p>

### 4.3 ELECTROSTATIC DISCHARGE IMMUNITY TEST (ESD)

#### 4.3.1 TEST SPECIFICATION

Basic Standard	IEC 61000-4-2
Discharge Impedance	330 ohm / 150 pF
Required Performance	B
Discharge Voltage	Air Discharge: $\pm 2\text{kV}$ , $\pm 4\text{kV}$ , $\pm 8\text{kV}$ Contact Discharge: $\pm 4\text{kV}$
Polarity	Positive & Negative
Number of Discharge	20 times at each test point
Discharge Mode	Single Discharge
Discharge Period	1 second

#### 4.3.2 MEASUREMENT INSTRUMENTS

Item	Kind of Equipment	Manufacturer	Type No.	Serial No.	Calibrated until
1	ESD Generator	TESEQ	NSG 437	1726	Sep. 25, 2024

Remark: "N/A" denotes no model name, no serial No. or no calibration specified.

All calibration period of equipment list is one year.

#### 4.3.3 TEST PROCEDURE

The test generator necessary to perform direct and indirect application of discharges to the EUT in the following manner:

- a. The test shall be performed with single discharges. On each pre-selected point at least 10 single discharges (in the most sensitive polarity) shall be applied.

NOTE 1 The minimum number of discharges applied is depending on the EUT; for products with synchronized circuits the number of discharges should be larger.

For the time interval between successive single discharges an initial value of 1 s is recommended. Longer intervals may be necessary to determine whether a system failure has occurred.

NOTE 2 The points to which the discharges should be applied may be selected by means of an exploration carried out at a repetition rate of 20 discharges per second, or more.

Vertical Coupling Plane (VCP):

The coupling plane, of dimensions 0.5m x 0.5m, is placed parallel to, and positioned at a distance 0.1m from, the EUT, with the Discharge Electrode touching the coupling plane.

The four faces of the EUT will be performed with electrostatic discharge.

Horizontal Coupling Plane (HCP):

The coupling plane is placed under to the EUT. The generator shall be positioned vertically at a distance of 0.1m from the EUT, with the Discharge Electrode touching the coupling plane.

The four faces of the EUT will be performed with electrostatic discharge.

- b. For TABLE-TOP equipment:

The configuration consisted of a wooden table 0.8 meters high standing on the Ground Reference Plane. The GRP consisted of a sheet of aluminum at least 0.25mm thick, and 2.5 meters square connected to the protective grounding system. A Horizontal Coupling Plane (1.6m x 0.8m) was placed on the table and attached to the GRP by means of a cable with 940k total impedance. The equipment under test was installed in a representative system as described in IEC 61000-4-2, and its cables were placed on the HCP and isolated by an insulating support of 0.5mm thickness. A distance of 1-meter minimum was provided between the EUT and the walls of the laboratory and any other metallic structure.

### 4.3.4 DEVIATION FROM TEST STANDARD

No deviation

### 4.3.5 TEST SETUP

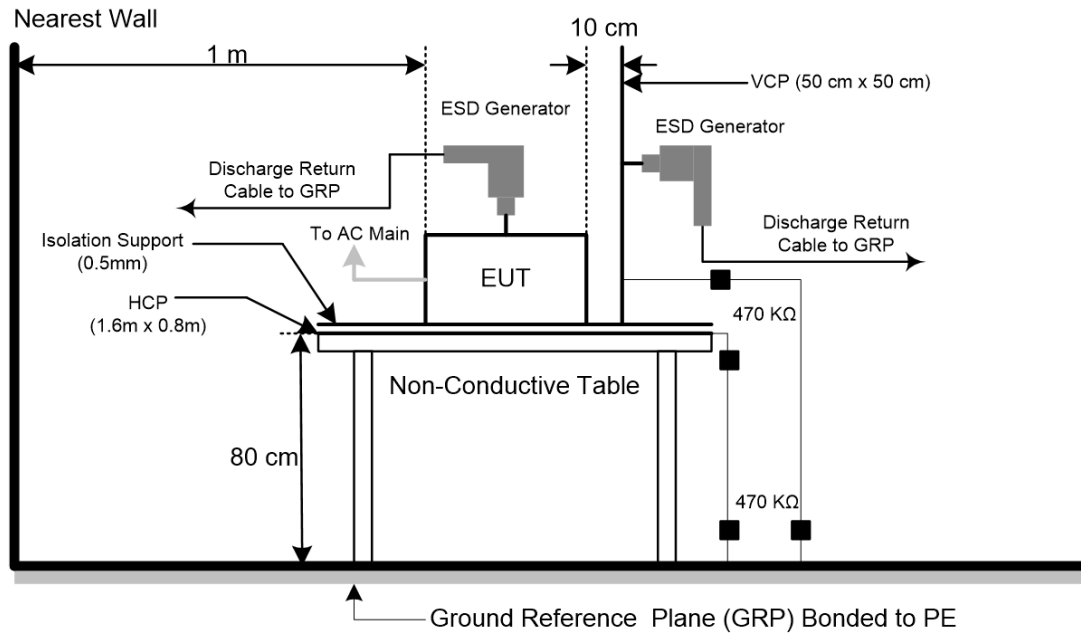

### 4.3.6 TEST RESULTS

Test Voltage	AC 230V/50Hz
Test Mode	Mode 1

Mode	Air Discharge								Contact Discharge						
	2kV		4kV		8kV		- kV		-kV		-kV		- kV		
Location	P	N	P	N	P	N	P	N	P	N	P	N	P	N	
1	A	A	A	A	A	A	-	-	-	-	-	-	-	-	
Criteria	B								-		B				-
Result	A								-		N/A				-

Mode	HCP Contact Discharge						VCP Contact Discharge						
	4kV		-kV		- kV		4kV		-kV		- kV		
Location	P	N	P	N	P	N	P	N	P	N	P	N	
Left side	A	A	-	-	-	-	A	A	-	-	-	-	
Right side	A	A	-	-	-	-	A	A	-	-	-	-	
Front side	A	A	-	-	-	-	A	A	-	-	-	-	
Rear side	A	A	-	-	-	-	A	A	-	-	-	-	
Criteria	B						-		B				-
Result	A						-		A				-

Note:

- 1) P/N denotes the Positive/Negative polarity of the output voltage.
- 2) N/A - denotes test is not applicable in this test report

PHOTO(S) SHOWN THE LOCATION(S) OF ESD EVALUATED

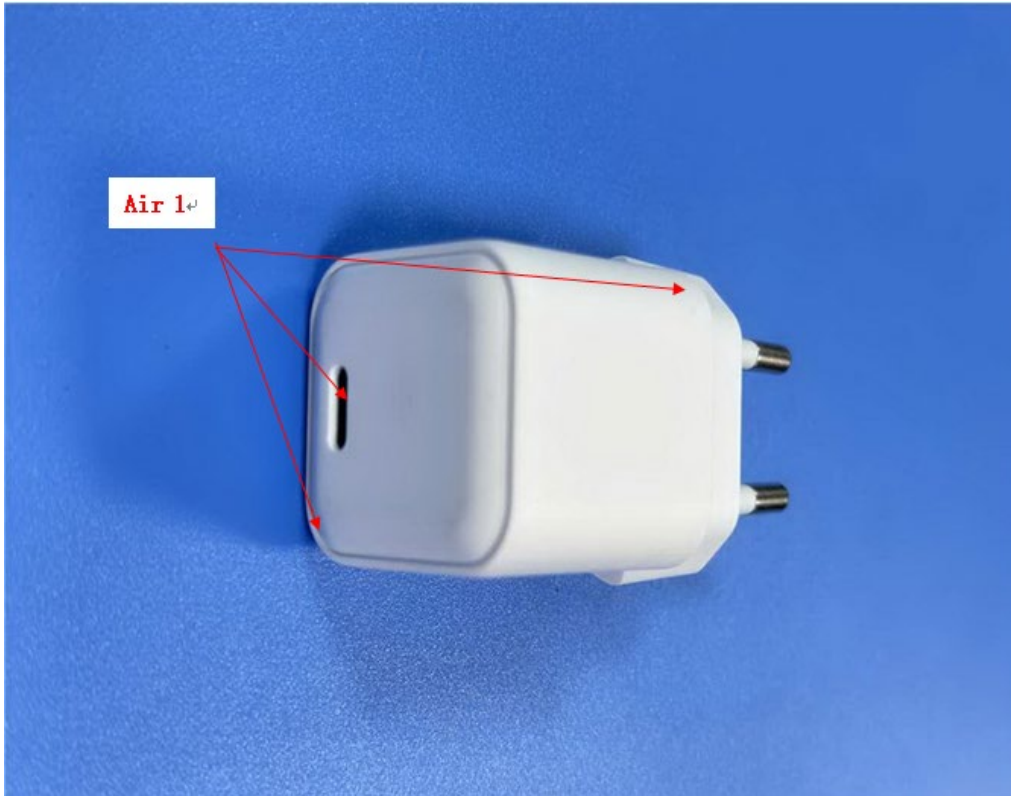

#### 4.4 RADIATED, RADIO-FREQUENCY, ELECTROMAGNETIC FIELD IMMUNITY TEST (RS)

##### 4.4.1 TEST SPECIFICATION

Basic Standard	IEC 61000-4-3
Required Performance	A
Frequency Range	80 MHz - 1000 MHz, 1800 MHz, 2600 MHz, 3500 MHz, 5000MHz ( $\pm 1\%$ )
Field Strength	3 V/m(unmodulated, r.m.s)
Modulation	1 kHz Sine Wave, 80%, AM Modulation
Frequency Step	1% of the preceding frequency.
Polarity of Antenna	Horizontal and Vertical
Test Distance	3 m
Antenna Height	1.55 m
Dwell Time	3 seconds

##### 4.4.2 MEASUREMENT INSTRUMENTS

Item	Kind of Equipment	Manufacturer	Type No.	Serial No.	Calibrated until
1	Stacked Double Log.-Per.Antenna	Schwarzbeck	STLP 9129	00210	N/A
2	Power amplifier	RFLIGHT	NTWPA-0081030 0	21113246	Jan. 19, 2025
3	Power amplifier	RFLIGHT	NTWPA-1060100 P	21123268	Jan. 19, 2025
4	MXG Vector Signal Generator	Keysight	N5181A	MY50144565	Jul. 07, 2024
5	Measurement Software	Tonscend	TS+	N/A	N/A

Remark: "N/A" denotes no model name, no serial No. or no calibration specified.

All calibration period of equipment list is one year.

##### 4.4.3 TEST PROCEDURE

The EUT and support equipment are in a fully-anechoic chamber.

The testing distance from antenna to the EUT was 3 meters.

For TABLE-TOP equipment:

The EUT installed in a representative system as described in IEC 61000-4-3 was placed on a non-conductive table 0.8 meters in height. The system under test was connected to the power and signal wire according to relevant installation instructions.

- a. The field strength level was 3 V/m(unmodulated, r.m.s).
- b. The frequency range is swept from 80 MHz to 1000 MHz, with the signal 80%amplitude modulated with a 1 kHz sine wave. Where the frequency range is swept incrementally, the step size was 1% of the preceding frequency.
- c. The dwell time at each frequency shall be not less than the time necessary for the EUT to be able to respond.
- d. The test was performed with the EUT exposed to both vertically and horizontally polarized fields on each of the four sides.

#### 4.4.4 DEVIATION FROM TEST STANDARD

No deviation

#### 4.4.5 TEST SETUP

a) For Continuous induced RF disturbances

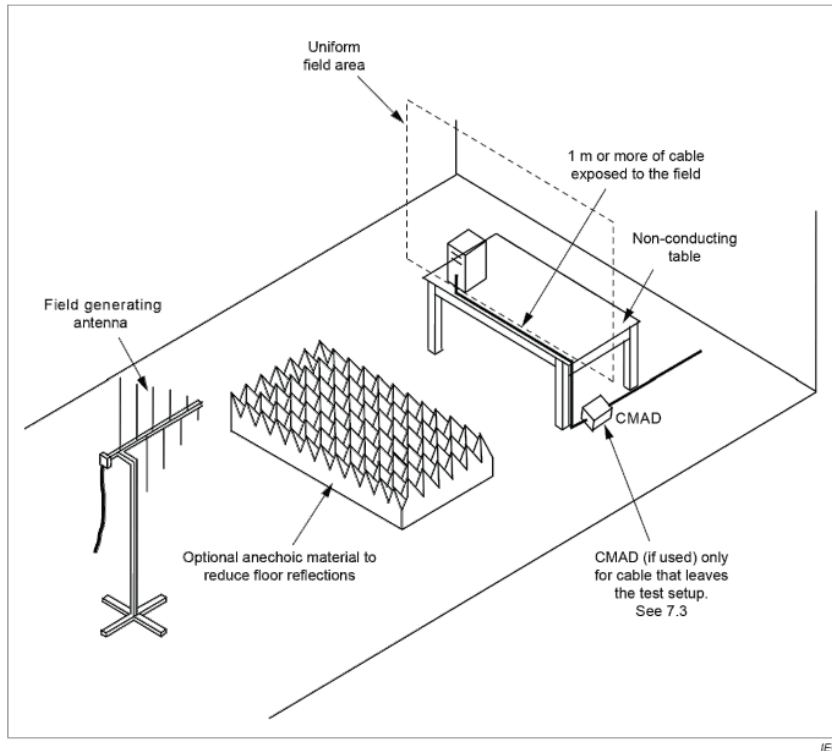

#### 4.4.6 TEST RESULTS

Test Voltage	AC 230V/50Hz
Test Mode	Mode 1

Frequency Range (MHz)	RF Field Position	R.F. Field Strength	Modulation	Azimuth	Criterion	Result
80 - 1000	H / V	3V/m	AM Modulated 1000Hz, 80%	0	A	A
				90		
				180		
				270		
1800, 2600, 3500, 5000 (±1%)	H / V	3V/m	AM Modulated 1000Hz, 80%	0	A	A
				90		
				180		
				270		

## 4.5 ELECTRICAL FAST TRANSIENT/BURST IMMUNITY TEST (EFT)

### 4.5.1 TEST SPECIFICATION

Basic Standard	IEC 61000-4-4
Required Performance	B
Test Voltage	AC mains power ports: $\pm 1$ kV
Polarity	Positive & Negative
Impulse Frequency	N/A
Impulse Wave shape	5/50 ns
Burst Duration	15 ms
Burst Period	300 ms
Test Duration	1 min.

### 4.5.2 MEASUREMENT INSTRUMENTS

Item	Kind of Equipment	Manufacturer	Type No.	Serial No.	Calibrated until
1	Fast Transient Burst Simulator	Prima	EFT61004TA	PR201843360	Jul. 07, 2024

Remark: "N/A" denotes no model name, no serial No. or no calibration specified.

All calibration period of equipment list is one year.

### 4.5.3 TEST PROCEDURE

For TABLE-TOP equipment:

The configuration consisted of a wooden table (0.8m high) standing on the Ground Reference Plane and should be located 0.1 m $\pm$  0.01m above the Ground Reference Plane. The GRP consisted of a sheet of aluminum (at least 0.25mm thick and 2.5m square) connected to the protective grounding system. A minimum distance of 0.5m was provided between the EUT and the walls of the laboratory or any other metallic structure.

- a. Both positive and negative polarity discharges were applied.
- b. The duration time of each test sequential was 1 minute.

### 4.5.4 DEVIATION FROM TEST STANDARD

No deviation

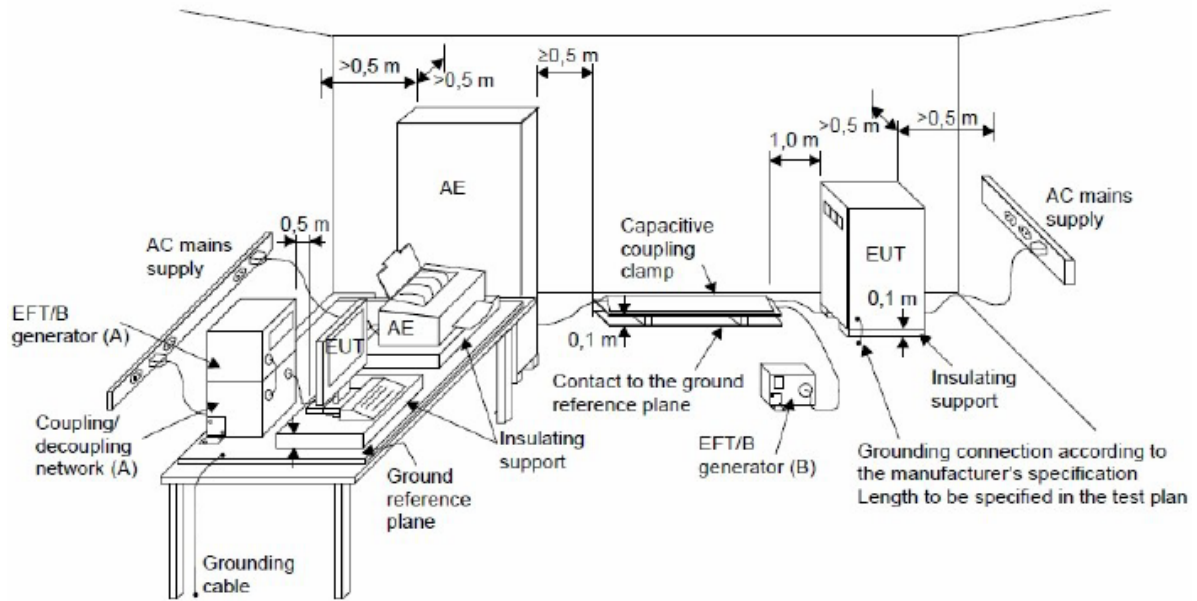
**4.5.5 TEST SETUP**

#### 4.5.6 TEST RESULTS

Test Voltage	AC 230V/50Hz
Test Mode	Mode 1

EUT Ports Tested		Polarity	Repetition Frequency	Test Level	Criterion	Result
				1kV		
AC Power Port	Line (L)	+	5 kHz	A	B	A
		-	5 kHz	A		
	Neutral (N)	+	5 kHz	A	B	A
		-	5 kHz	A		
	L+N	+	5 kHz	A	B	A
		-	5 kHz	A		

## 4.6 SURGE IMMUNITY TEST (SURGE)

### 4.6.1 TEST SPECIFICATION

Basic Standard	IEC 61000-4-5
Required Performance	B(AC mains power ports)
Wave-Shape	1.2/50(8/20) Tr/Th $\mu$ s combination wave
Test Voltage	AC mains power ports: $\pm 0.5$ kV, $\pm 1$ kV
Generator Source Impedance	2 $\Omega$ of the low-voltage power supply network.
Phase Angle, Polarity and Number of Tests	Five positive pulses line-to-neutral at 90° phase Five negative pulses line-to-neutral at 270° phase
Pulse Repetition Rate	1 time / min

### 4.6.2 MEASUREMENT INSTRUMENTS

Item	Kind of Equipment	Manufacturer	Type No.	Serial No.	Calibrated until
1	Lightning Surge Generator	Prima	SUG61005TB	PR210655102	Jul. 07, 2024
2	Measurement Software	Prima	SUG_Series	N/A	N/A

Remark: "N/A" denotes no model name, no serial No. or no calibration specified.

All calibration period of equipment list is one year.

### 4.6.3 TEST PROCEDURE

a. For EUT power supply:

The surge is to be applied to the EUT power supply terminals via the capacitive coupling network. Decoupling networks are required in order to avoid possible adverse effects on equipment not under test that may be powered by the same lines, and to provide sufficient decoupling impedance to the surge wave. The power cord between the EUT and the coupling/decoupling networks shall be 2 meters in length (or shorter).

b. For test applied to unshielded unsymmetrically operated interconnection lines of EUT :

The surge is applied to the lines via the capacitive coupling. The coupling /decoupling networks shall not influence the specified functional conditions of the EUT. The interconnection line between the EUT and the coupling/decoupling networks shall be 2 meters in length (or shorter).

c. For test applied to unshielded symmetrically operated interconnection /telecommunication lines of EUT :

The surge is applied to the lines via gas arrestors coupling. Test levels below the ignition point of the coupling arrestor cannot be specified. The interconnection line between the EUT and the coupling/decoupling networks shall be 2 meters in length (or shorter).

### 4.6.4 DEVIATION FROM TEST STANDARD

No deviation

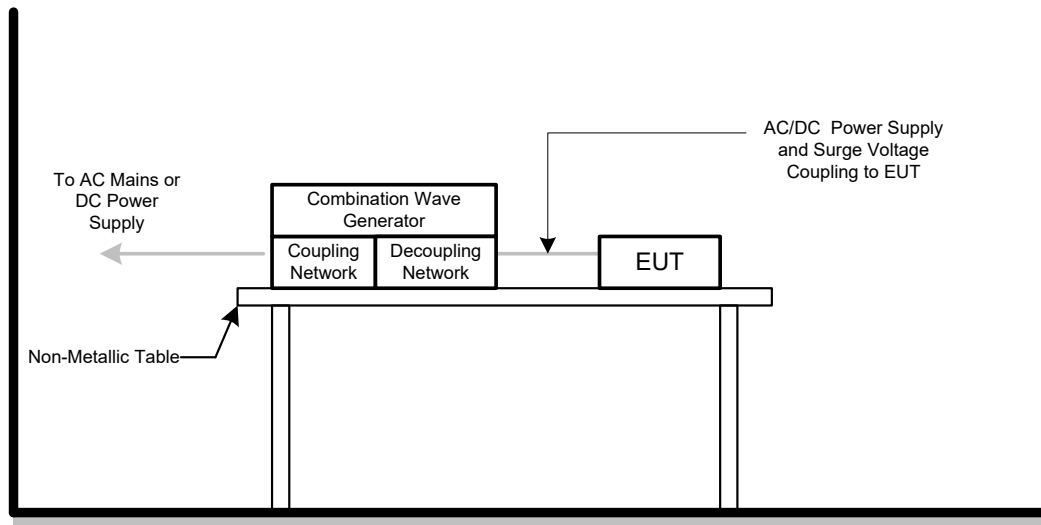
**4.6.5 TEST SETUP**

#### 4.6.6 TEST RESULTS

Test Voltage	AC 230V/50Hz
Test Mode	Mode 1

Wave Form EUT Ports Tested		1.2/50(8/20)Tr/Th $\mu$ s						Criterion	Result
		Polarity	Phase	Voltage					
				0.5kV	1kV	-- kV	-- kV		
AC	L - N	+	90°	A	A	-	-	B	A
		-	270°	A	A	-	-		

## 4.7 IMMUNITY TO CONDUCTED DISTURBANCES, INDUCED BY RADIO-FREQUENCY FIELDS TEST (CS)

### 4.7.1 TEST SPECIFICATION

Basic Standard	IEC 61000-4-6
Required Performance	A
Frequency Range&Field Strength	0.15 MHz - 10 MHz: 3V (unmodulated, r.m.s.) 10 MHz - 30 MHz: 3V to 1V (unmodulated, r.m.s.) 30 MHz - 80 MHz: 1V (unmodulated, r.m.s.)
Modulation	1 kHz Sine Wave, 80%, AM Modulation
Frequency Step	1 % of the preceding frequency value
Dwell Time	3 seconds

### 4.7.2 MEASUREMENT INSTRUMENTS

Item	Kind of Equipment	Manufacturer	Type No.	Serial No.	Calibrated until
1	Test system for conducted immunity	TESEQ	NSG4070	61322	Jul. 07, 2024
2	Measurement Software	Farad	EZ-CS (Ver:B-3.1)	N/A	N/A
3	Coupling Decoupling Network	TESEQ	CDN M016	61183	Jul. 07, 2024

Remark: "N/A" denotes no model name, no serial No. or no calibration specified.

All calibration period of equipment list is one year.

### 4.7.3 TEST PROCEDURE

The EUT and support equipment, are placed on a table that is 0.8 meter above a metal ground plane measured 1m\*1m min. and 0.65mm thick min.

The other condition as following manner:

- a. The field strength level was 3 V (unmodulated, r.m.s.)
- b. The frequency range is swept from 150 kHz to 80 MHz, with the signal 80%amplitude modulated with a 1 kHz sinewave. Where the frequency range is swept incrementally, the step size shall not exceed 1 % of the preceding frequency value.
- c. The dwell time at each frequency shall be not less than the time necessary for the EUT to be able to respond.

### 4.7.4 DEVIATION FROM TEST STANDARD

No deviation

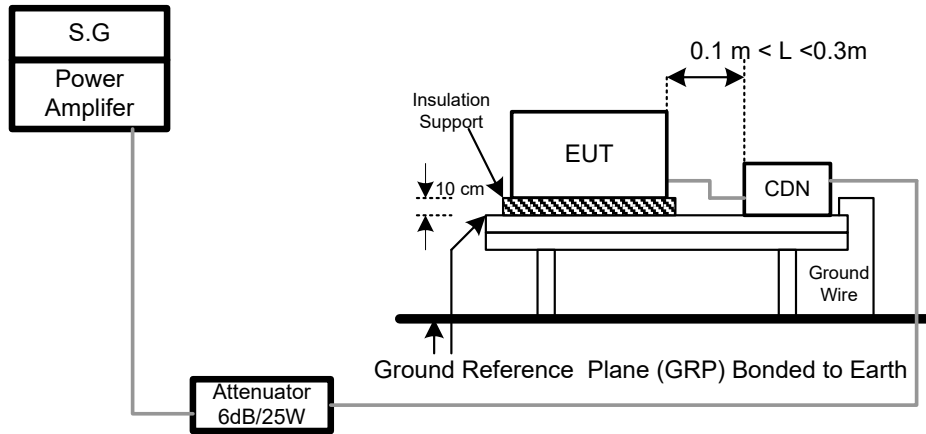
**4.7.5 TEST SETUP**

**4.7.6 TEST RESULTS**

Test Voltage	AC 230V/50Hz
Test Mode	Mode 1

Test Ports (Mode)	Freq.Range (MHz)	Field Strength	Modulation	Criteria	Results
AC mains power ports	0.15 - 10	3V	AM Modulated 1000Hz, 80%	A	A
	10 - 30	3V to 1V			
	30 - 80	1V			

## 4.8 POWER FREQUENCY MAGNETIC FIELD IMMUNITY TEST (PFMF)

### 4.8.1 TEST SPECIFICATION

Basic Standard	IEC 61000-4-8
Required Performance	A
Frequency Range	50/60Hz
Field Strength	1 A/m
Observation Time	1 minute
Inductance Coil	Rectangular type, 1mx1m

### 4.8.2 MEASUREMENT INSTRUMENTS

Item	Kind of Equipment	Manufacturer	Type No.	Serial No.	Calibrated until
1	Power frequency magnetic field interferes with main engine	3ctest	MFS 400	ES045000821 015	Aug. 14, 2024
2	Magnetic field generator module	3ctest	MFT400	ES046000121 015	Aug. 14, 2024
3	magnetic field coil	3ctest	TCXS111	TCXS210709 24	Aug. 14, 2024

Remark: "N/A" denotes no model name, no serial No. or no calibration specified.

All calibration period of equipment list is one year.

### 4.8.3 TEST PROCEDURE

For TABLE-TOP equipment:

The equipment shall be subjected to the test magnetic field by using the induction coil of standard dimension (1 m x 1 m). The induction coil shall then be rotated by 90 degrees in order to expose the EUT to the test field with different orientations.

The other condition as following manner:

- a. The equipment cabinets shall be connected to the safety earth directly on the GRP via the earth terminal of the EUT.
- b. The cables supplied or recommended by the equipment manufacturer shall be used. 1 meter of all cables used shall be exposed to the magnetic field.

### 4.8.4 DEVIATION FROM TEST STANDARD

No deviation

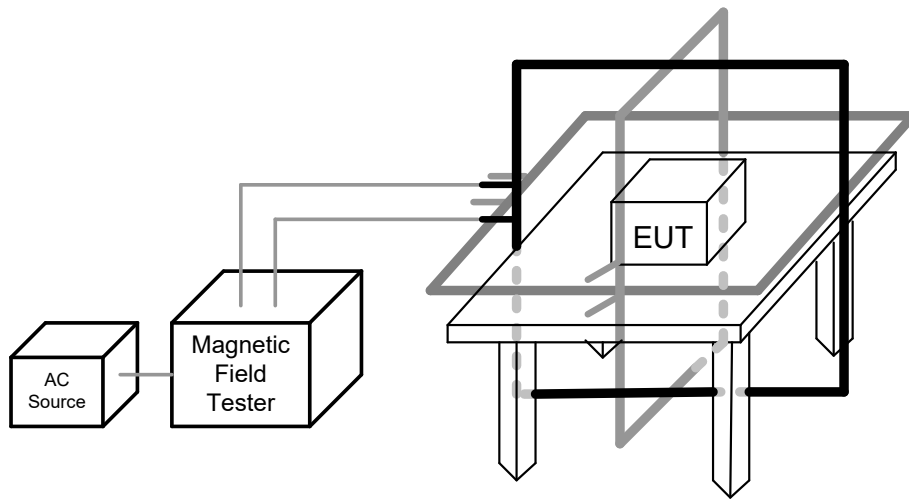
**4.8.5 TEST SETUP**

**4.8.6 TEST RESULTS**

Test Voltage	AC 230V/50Hz
Test Mode	Mode 1

## 50Hz

Test Mode	Test Level	Antenna aspect	Duration	Criteria	Results
Enclosure	1 A/m	X	60s	A	A
Enclosure	1 A/m	Y	60s	A	A
Enclosure	1 A/m	Z	60s	A	A

## 60Hz

Test Mode	Test Level	Antenna aspect	Duration	Criteria	Results
Enclosure	1 A/m	X	60s	A	A
Enclosure	1 A/m	Y	60s	A	A
Enclosure	1 A/m	Z	60s	A	A

## 4.9 VOLTAGE DIPS, SHORT INTERRUPTIONS AND VOLTAGE VARIATIONS IMMUNITY TEST (DIPS)

### 4.9.1 TEST SPECIFICATION

Basic Standard	IEC 61000-4-11
Required Performance	Voltage dips: B (For <5% residual voltage, dips) C (For 70% residual voltage, dips) C (For <5% residual voltage, Interruptions)
Interval between Event	Ten seconds
Phase Angle	0°/180°
Test Cycle	3 times

### 4.9.2 MEASUREMENT INSTRUMENTS

Item	Kind of Equipment	Manufacturer	Type No.	Serial No.	Calibrated until
1	Cycle Sag Simulator	Prima	DRP61011TA	PR21076614	Jul. 07, 2024

Remark: "N/A" denotes no model name, no serial No. or no calibration specified.

All calibration period of equipment list is one year.

### 4.9.3 TEST PROCEDURE

The EUT shall be tested for each selected combination of test levels and duration with a sequence of three dips/interruptions with intervals of 10 s minimum (between each test event). Each representative mode of operation shall be tested. Abrupt changes in supply voltage shall occur at zero crossings of the voltage waveform.

### 4.9.4 DEVIATION FROM TEST STANDARD

No deviation

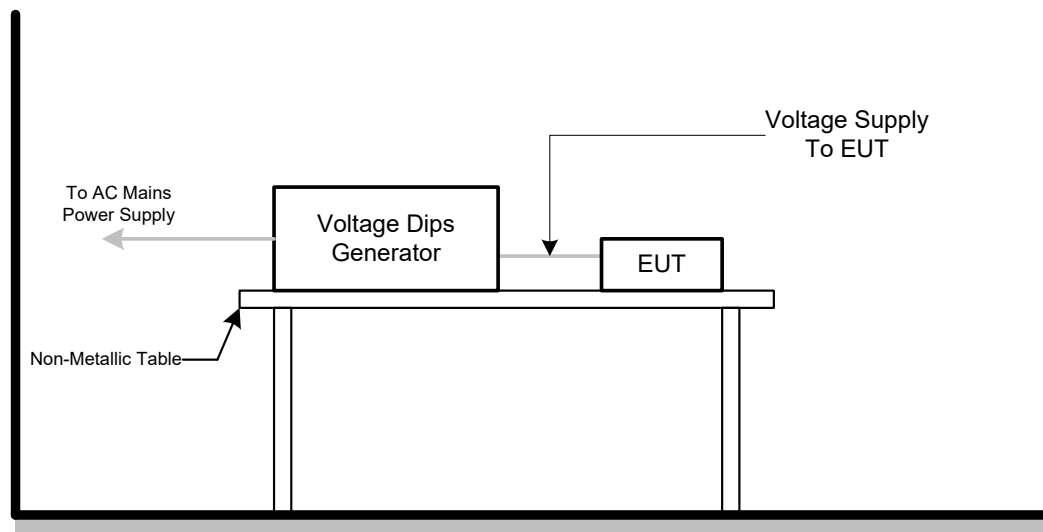
**4.9.5 TEST SETUP**

#### 4.9.6 TEST RESULTS

Test Voltage	AC 100V/50Hz, AC 230V/50Hz, AC 240V/50Hz
Test Mode	Mode 1

AC 100V/50Hz				
Item	Residual Voltage	Cycle	Criteria	Results
Voltage dips	<5%	0.5	B	A
Voltage dips	70%	25	C	A
Voltage Interruption	<5%	250	C	C

AC 230V/50Hz				
Item	Residual Voltage	Cycle	Criteria	Results
Voltage dips	<5%	0.5	B	A
Voltage dips	70%	25	C	A
Voltage Interruption	<5%	250	C	C

AC 240V/50Hz				
Item	Residual Voltage	Cycle	Criteria	Results
Voltage dips	<5%	0.5	B	A
Voltage dips	70%	25	C	A
Voltage Interruption	<5%	250	C	C

**5. EUT TEST PHOTO**

Radiated emissions up to 1 GHz

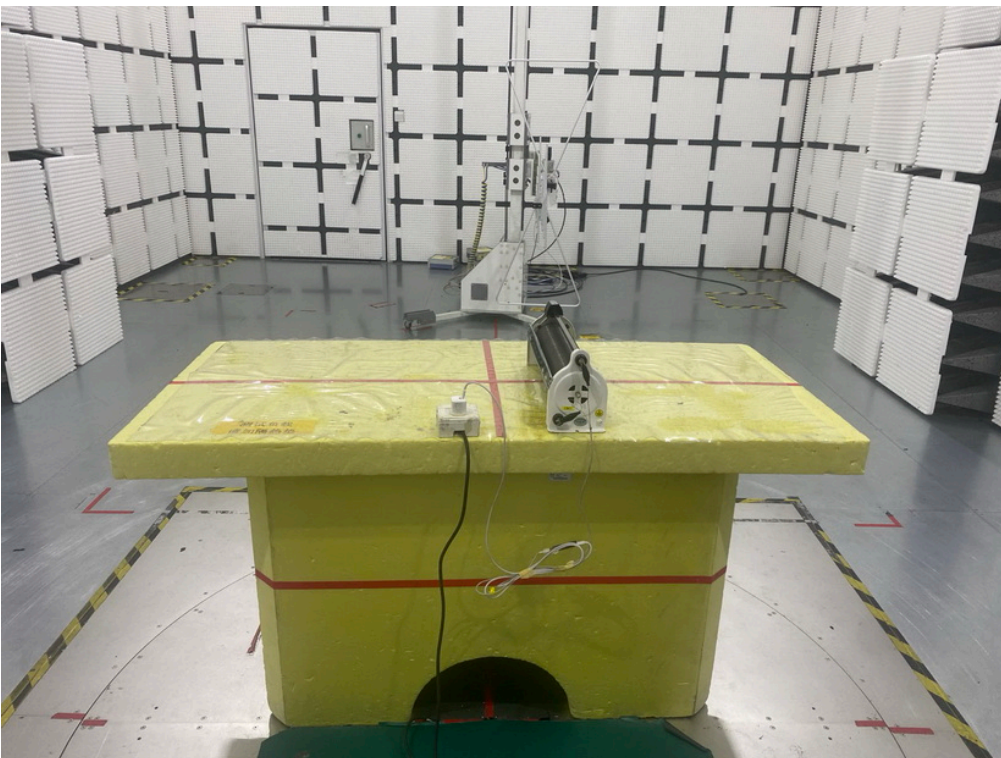
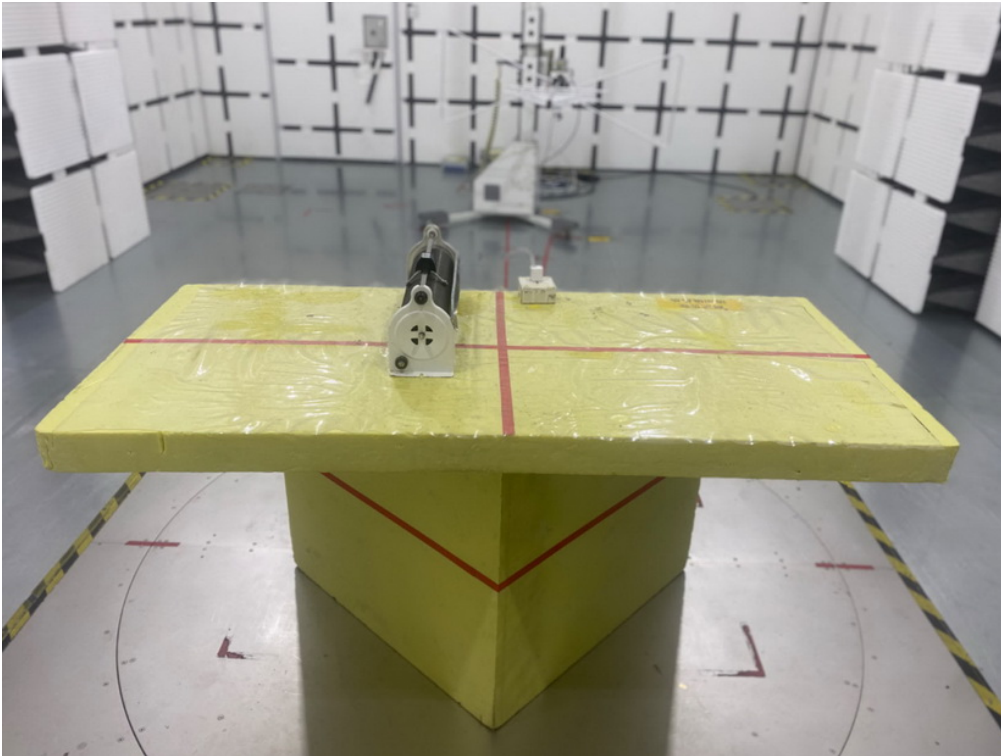

Conducted emissions AC mains power port

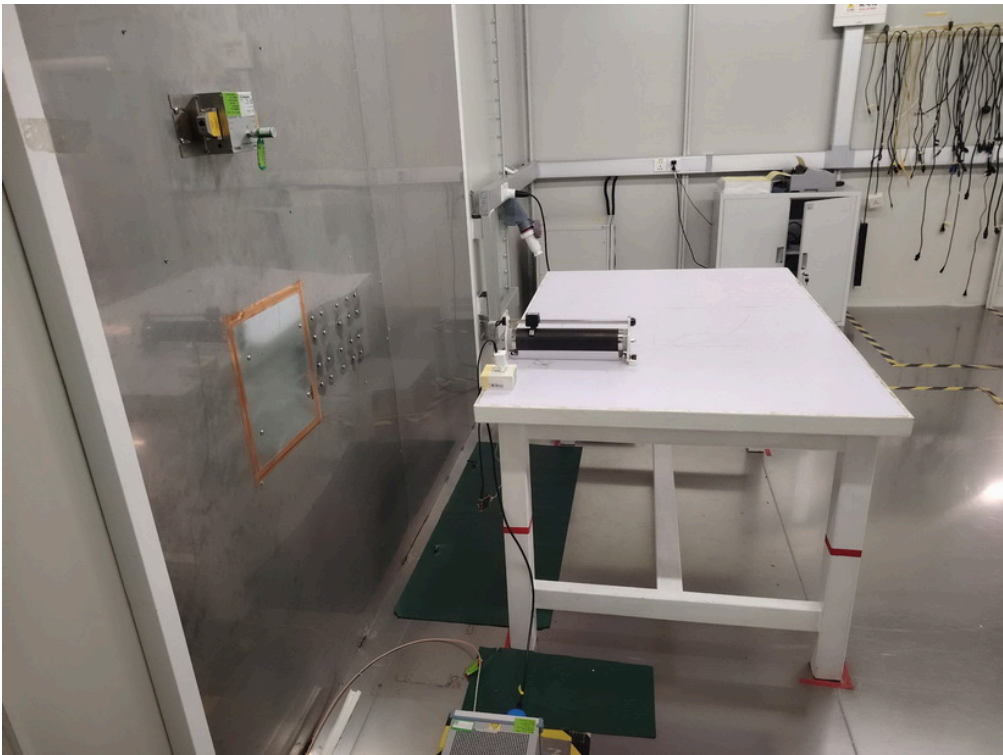
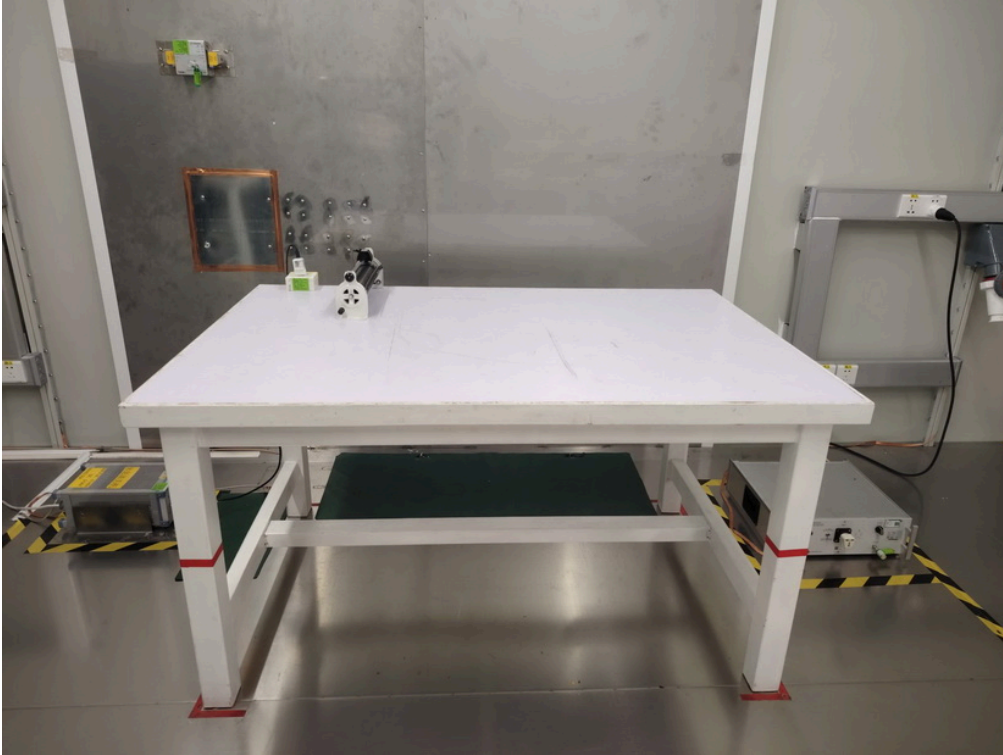

Harmonic current

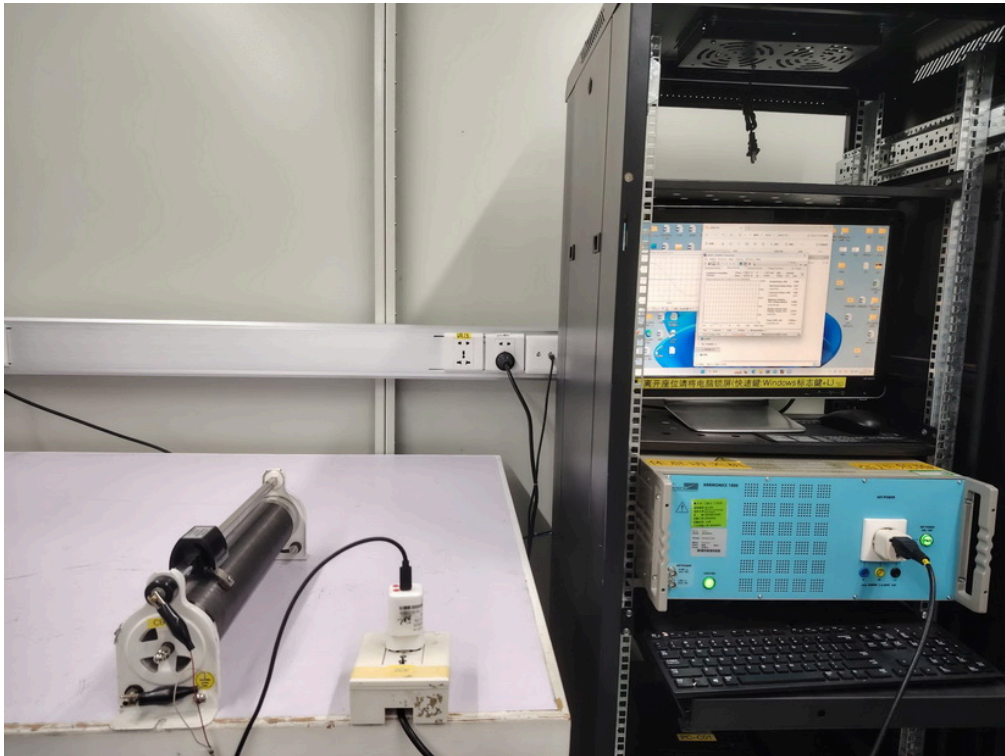

Voltage fluctuations (Flicker)

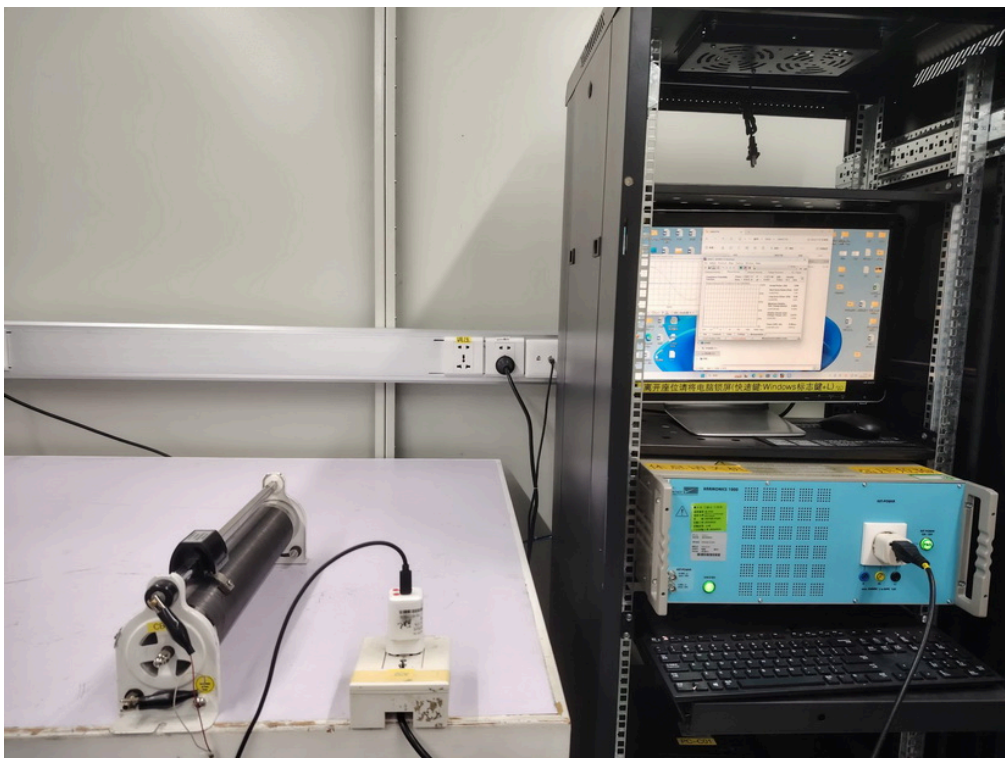

Electrostatic discharge immunity



Radiated, radio-frequency, electromagnetic field immunity – Up to 1GHz

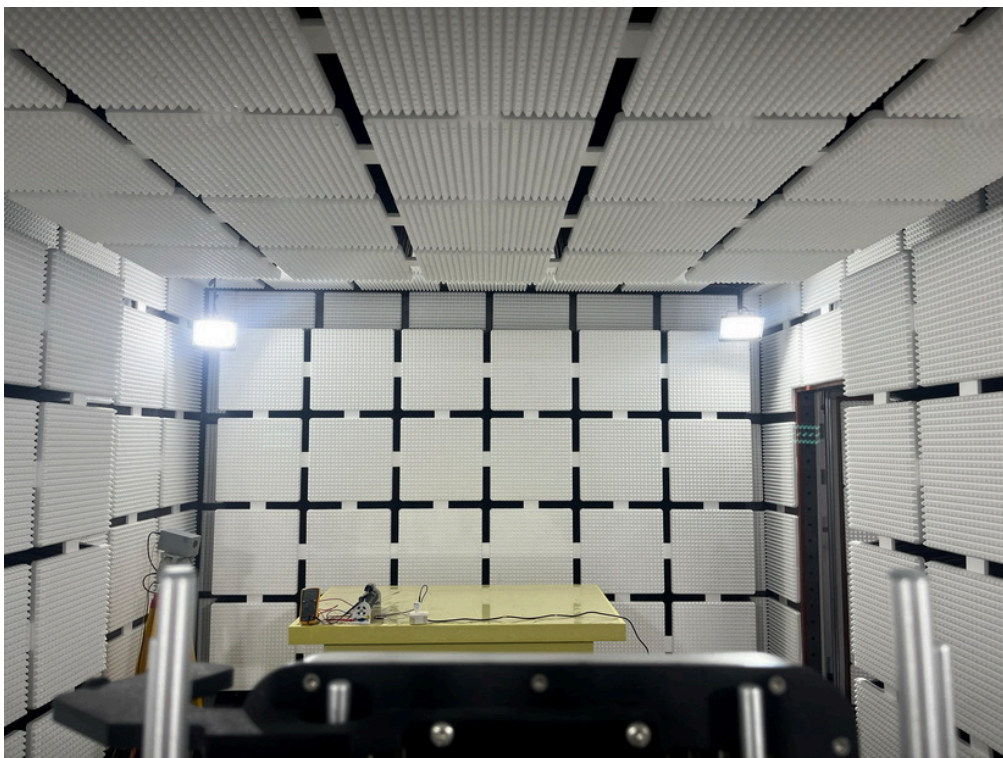

## Radiated, radio-frequency, electromagnetic field immunity – Above 1GHz

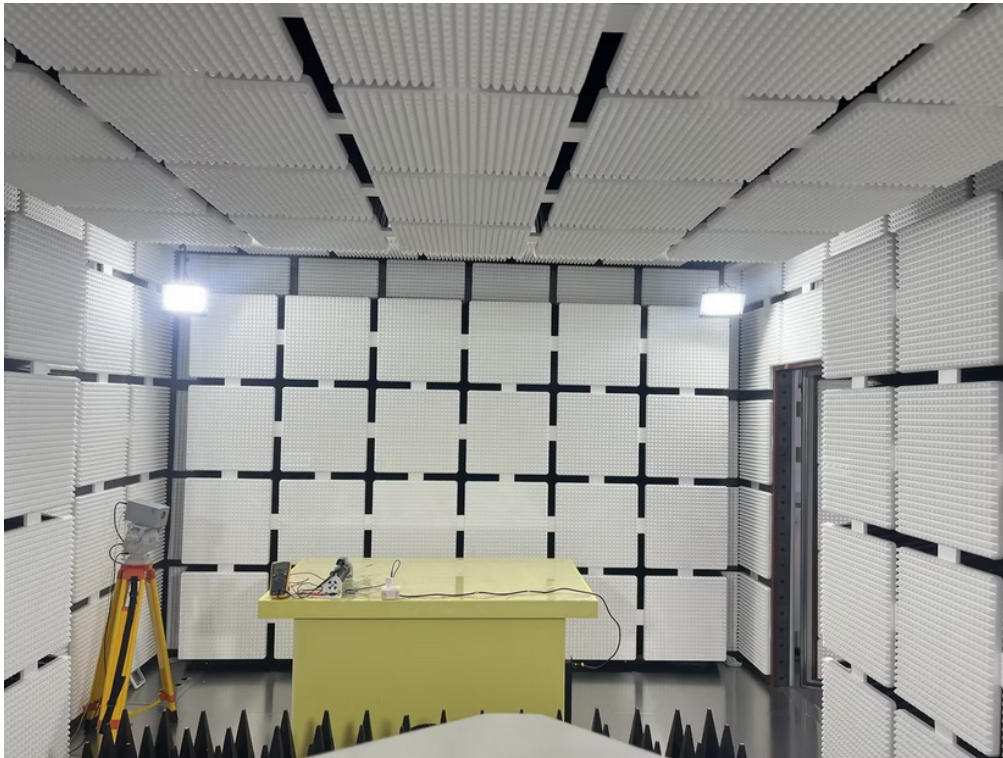

## Electrical fast transient/burst immunity - AC

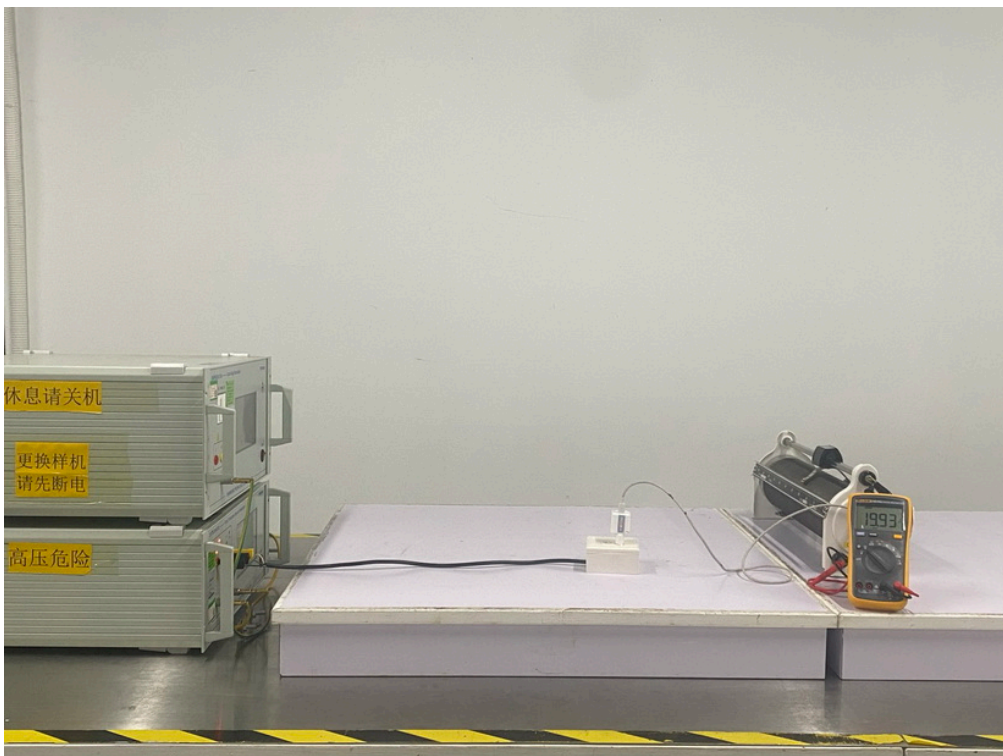

## Surge immunity - AC

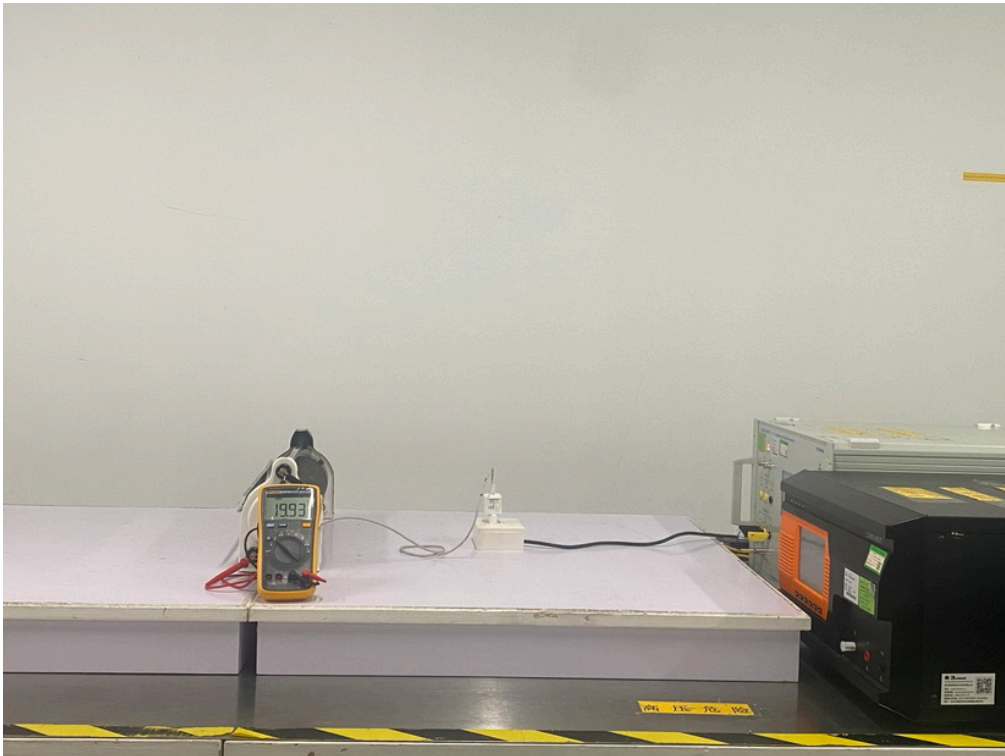

## Immunity to conducted disturbances, induced by radio-frequency fields - AC

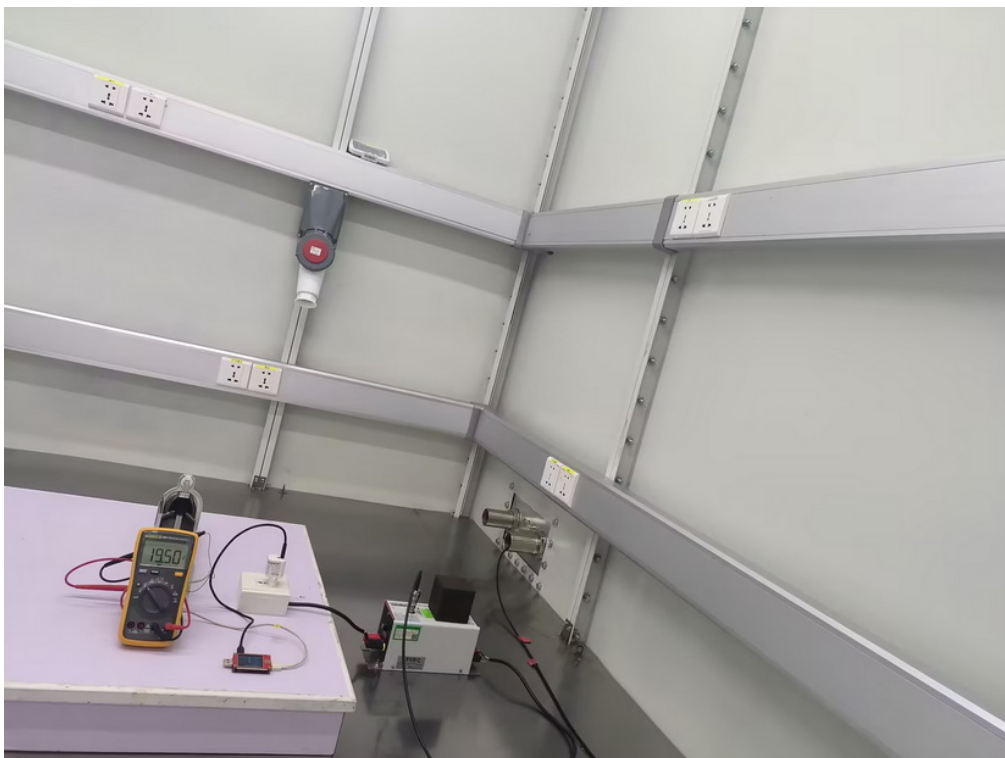

Power frequency magnetic field immunity

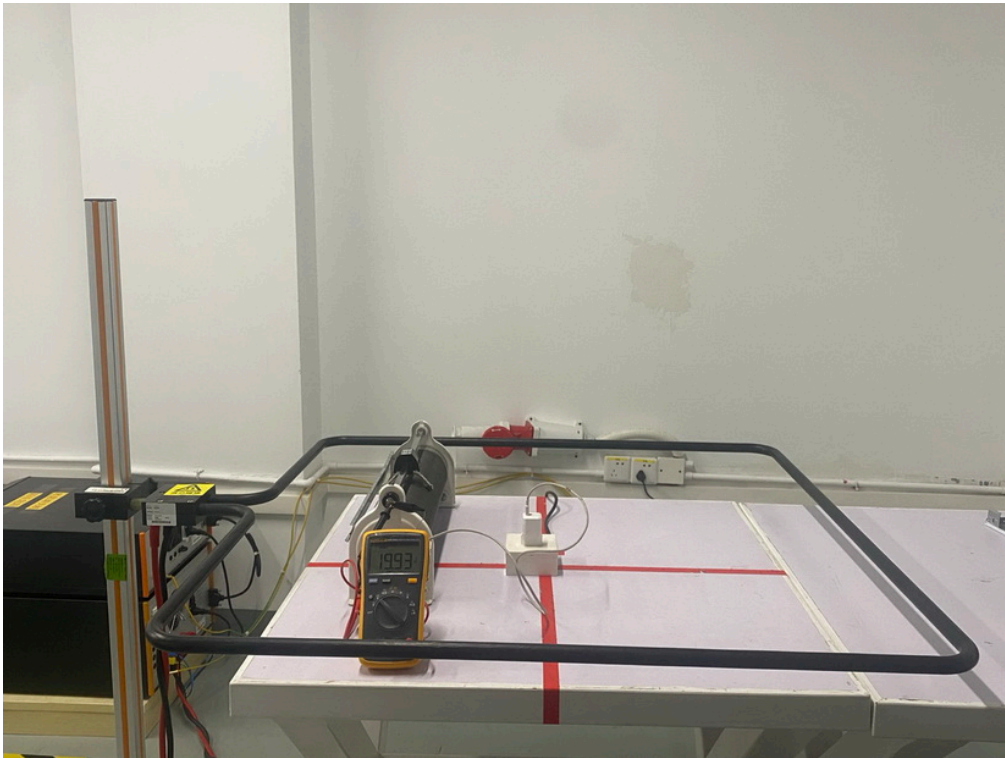

Voltage dips, short interruptions and voltage variations immunity

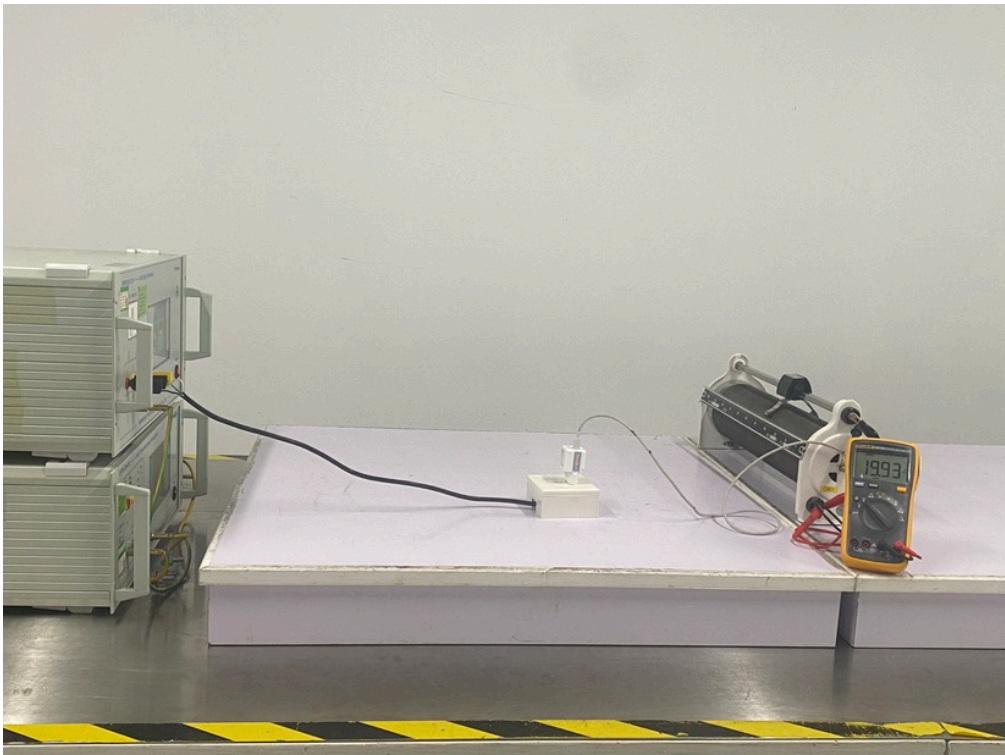

**End of Test Report**