



中国认可
国际互认
检测
TESTING
CNAS L4595

TEST REPORT BS EN IEC 62368-1 Audio/video, information and communication technology equipment Part 1: Safety requirements	
Report Number.....:	LCSA09294071S
Date of issue.....:	2024-10-22
Total number of pages.....:	92
Name of Testing Laboratory preparing the Report.....:	Shenzhen LCS Compliance Testing Laboratory Ltd.
Applicant's name.....:	Suparo Industries Ltd
Address.....:	Weir Street, Blackburn, BB2 2AN, United Kingdom
Test specification:	
Standard.....:	BS EN IEC 62368-1:2020+A11:2020
Test procedure.....:	Type test
Non-standard test method.....:	N/A
TRF template used.....:	IECEE OD-2020-F1:2021, Ed.1.4
Test Report Form No.....:	TRF-4-S-132 A/0
Test Report Form(s) Originator.....:	UL(US)
Master TRF.....:	Dated 2022-04-14
Copyright © 2022 IEC System of Conformity Assessment Schemes for Electrotechnical Equipment and Components (IECEE System). All rights reserved. This publication may be reproduced in whole or in part for non-commercial purposes as long as the IECEE is acknowledged as copyright owner and source of the material. IECEE takes no responsibility for and will not assume liability for damages resulting from the reader's interpretation of the reproduced material due to its placement and context.	
General disclaimer:	
The test results presented in this report relate only to the object tested. This report shall not be reproduced, except in full, without the written approval of the Issuing Testing Laboratory. The authenticity of this Test Report and its contents can be verified by contacting the Testing Laboratory, responsible for this Test Report.	





Test item description:	100W Triple USB-C & USB-A Wall Charger
Trade Mark(s):	
Manufacturer:	Foshan G-Power Technology Co., LTD B4-601, 602, 603, 604, 702, 704, SXC, No. 1 Fusheng West Road, Dafuji Community, Ronggui Street, Shunde District, Foshan City, 528300, Guangdong Province, China
Model/Type reference:	S100W
Ratings:	See label for details on page 4

Responsible Testing Laboratory (as applicable), testing procedure and testing location(s):

<input checked="" type="checkbox"/>	Testing Laboratory:	Shenzhen LCS compliance testing laboratory Ltd.	
	Testing location/ address:	Room 101, 201, Building A and Room 301, Building C, Juji Industrial Park, Yabianxueziwei, Shajing Street, Bao'an District, Shenzhen, Guangdong, China	
	Prepared by:	Mona Tao Project Handler	
	Checked by:	Benson Kuai Reviewer	
	Approved by:	Hart Qiu Technical Director	





List of Attachments (including a total number of pages in each attachment):

- Attachment No. 1: BRITAIN GROUP DIFFERENCES AND NATIONAL DIFFERENCES.
- Attachment No. 2: BS plug test
- Attachment No. 3: Photo Documentation

Summary of testing:

Tests performed (name of test and test clause):

Electrical safety:

- BS EN IEC 62368-1:2020+A11:2020

Testing location:

Shenzhen LCS Compliance Testing Laboratory Ltd.
 Room 101, 201, Building A and Room 301, Building C, Juji Industrial Park, Yabianxueziwei, Shajing Street, Bao'an District, Shenzhen, Guangdong, China

Summary of compliance with National Differences:

List of countries addressed: National Differences and Group Differences as refer to Attachment No. 1.

- The product fulfils the requirements of **BS EN IEC 62368-1:2020+A11:2020**

Use of uncertainty of measurement for decisions on conformity (decision rule) :

- No decision rule is specified by the IEC standard, when comparing the measurement result with the applicable limit according to the specification in that standard. The decisions on conformity are made without applying the measurement uncertainty ("simple acceptance" decision rule, previously known as "accuracy method").
- Other:... (to be specified, for example when required by the standard or client, or if national accreditation requirements apply)

Information on uncertainty of measurement:

The uncertainties of measurement are calculated by the laboratory based on application of criteria given by OD-5014 for test equipment and application of test methods, decision sheets and operational procedures of IECEE.

IEC Guide 115 provides guidance on the application of measurement uncertainty principles and applying the decision rule when reporting test results within IECEE scheme, noting that the reporting of the measurement uncertainty for measurements is not necessary unless required by the test standard or customer.

Calculations leading to the reported values are on file with the NCB and testing laboratory that conducted the testing.











Copy of marking plate:

The artwork below may be only a draft. The use of certification marks on a product must be authorized by the respective NCBs that own these marks.

suparo

<p>100W Triple USB-C & USB-A Wall Charger Model: S100W Input: AC 100-240V 50/60Hz 2.5A USB-C1/C2 Output: 5.0V= 3.0A, 9.0V= 3.0A, 12.0V= 3A,15.0V= 3.0A, 20.0V= 5.0A Max 100W PPS: 3.3-11V= 4A USB-C3 Output: 5.0V= 3.0A, 9.0V= 2.22A, 12.0V= 1.67A Max 20W USB-A1 Output: 5.0V= 3.0A, 9.0V= 2.0A, 12.0V= 1.5A Max 18W Suparo Industries Ltd. Weir Street, Blackburn, BB2 2AN, United Kingdom Made in China Manufacturer: Foshan G-Power Technology Co.,LTD B4-601, 602, 603, 604, 702, 704, SXC, No. 1 Fusheng West Road, Dafuji Community, Ronggui Street, Shunde District, Foshan City, 528300, Guangdong Province, China</p>	     
---	---

Notes:

1. The height dimension of CE & UKCA symbol should not less than 5mm, the height dimension of WEEE symbol should not less than 7mm.





Test item particulars:

Product group : end product built-in component

Classification of use by..... : Ordinary person
 Instructed person
 Skilled person
 Children likely to be present

Supply connection..... : AC Mains DC Mains
 External Circuit - not Mains connected
- ES1 ES2 ES3

Supply tolerance : +10%/-10%
 +20%/-15%
 + ___ %/ - ___ %
 None

Supply connection – type : pluggable equipment type A -
 non-detachable supply cord
 appliance coupler
 direct plug-in
 pluggable equipment type B -
 non-detachable supply cord
 appliance coupler
 permanent connection
 mating connector
 other: Not directly connected to the mains

Considered current rating of protective device..... : 16A
location: building; equipment; N/A

Equipment mobility..... : movable hand-held transportable
 direct plug-in stationary for building-in
 wall/ceiling-mounted SRME/rack-mounted
 other:

Overvoltage category (OVC) : OVC I OVC II OVC III
 OVC IV other:

Class of equipment : Class I Class II Class III
 Not classified

Special installation location : N/A restricted access area
 outdoor location

Pollution degree (PD) : PD 1 PD 2 PD 3

Manufacturer’s specified T_{ma}..... : 25 °C Outdoor: minimum °C

IP protection class : IPX0 IP___

Power systems : TN TT IT - ___ V_{L-L}
 not AC mains

Altitude during operation (m) : 2000 m or less ___ m

Altitude of test laboratory (m) : 500 m or less ___ m





Mass of equipment (kg) : 0.17kg

Possible test case verdicts:

- test case does not apply to the test object.... : N/A
- test object does meet the requirement..... : P (Pass)
- test object does not meet the requirement.... : F (Fail)

Testing:

Date of receipt of test item..... : 2022-08-19

Date (s) of performance of tests..... : From 2022-08-19 to 2022-09-10

General remarks:

"(See Enclosure #)" refers to additional information appended to the report.
 "(See appended table)" refers to a table appended to the report.

Throughout this report a comma / point is used as the decimal separator.

These marked "☆" test clauses are not within the scope of CNAS recognition.

The applicant and manufacturer information, product name, model, trademark and other information in this report are all provided by the applicant, and this laboratory is not responsible for verifying its authenticity.

Manufacturer's Declaration per sub-clause 4.2.5 of IEC60335-1:

The application for obtaining a CB Test Certificate includes more than one factory location and a declaration from the Manufacturer stating that the sample(s) submitted for evaluation is (are) representative of the products from each factory has been provided..... :	<input type="checkbox"/> Yes <input checked="" type="checkbox"/> Not applicable
--	--

When differences exist; they shall be identified in the General product information section.

Name and address of factory (ies)..... : Same as manufacturer

General product information and other remarks:

1. The maximum ambient temperature is 25°C.
2. This equipment is intended to operate in an area which has an elevation of maximum 2000m.
3. This report is based on LCS report No.: LCSA081922026S to issue a new test report. The product is identical to the previous evaluated product with no tests added. and the following changed:
 - Changed model name.
 - Changed product name.
 - Added trade mark.
 - Changed company name and address of applicant, manufacturer and factory.
 - Updated product label.





OVERVIEW OF ENERGY SOURCES AND SAFEGUARDS				
Clause	Possible Hazard			
5	Electrically-caused injury			
Class and Energy Source (e.g. ES3: Primary circuit)	Body Part (e.g. Ordinary)	Safeguards		
		B	S	R
ES3: Primary circuits supplied by a.c. mains supply	Ordinary	N/A	N/A	Y1-capacitor Transformer Enclosure
ES1: Secondary output	Ordinary	N/A	N/A	N/A
6	Electrically-caused fire			
Class and Energy Source (e.g. PS2: 100 Watt circuit)	Material part (e.g. Printed board)	Safeguards		
		B	1 st S	2 nd S
PS3: All primary circuits	All combustible materials within equipment fire enclosure	Equipment safeguard (e.g., no ignition occurs; no parts exceeding 90% of its spontaneous ignition temperature)	Equipment safeguard (e.g., control of fire spread; PCB is complied with V-0 material; All other components at least V-2 except for mounted on min. V-1 material or small parts of combustible material)	N/A
7	Injury caused by hazardous substances			
Class and Energy Source (e.g. Ozone)	Body Part (e.g., Skilled)	Safeguards		
		B	S	R
N/A	N/A	N/A	N/A	N/A
8	Mechanically-caused injury			
Class and Energy Source (e.g. MS3: Plastic fan blades)	Body Part (e.g. Ordinary)	Safeguards		
		B	S	R
MS1: less than 7kg (Mass of the unit)	Ordinary	N/A	N/A	N/A
MS1: Edges and corners	Ordinary	N/A	N/A	N/A
9	Thermal burn			
Class and Energy Source (e.g. TS1: Keyboard caps)	Body Part (e.g., Ordinary)	Safeguards		
		B	S	R
TS1: Plastic enclosure	Ordinary	N/A	N/A	N/A
TS3: Internal parts / circuits	Ordinary	N/A	N/A	N/A



10	Radiation			
Class and Energy Source (e.g. RS1: PMP sound output)	Body Part (e.g., Ordinary)	Safeguards		
		B	S	R
RS1: Indicator LED	Ordinary	N/A	N/A	N/A
Supplementary Information:				
"B" – Basic Safeguard; "S" – Supplementary Safeguard; "R" – Reinforced Safeguard				

ENERGY SOURCE DIAGRAM

Optional. Manufacturers are to provide the energy sources diagram identify declared energy sources and identifying the demarcations are between power sources. Recommend diagram be provided included in power supply and multipart systems.

Insert diagram below. Example diagram designs are; Block diagrams; image(s) with layered data; mechanical drawings

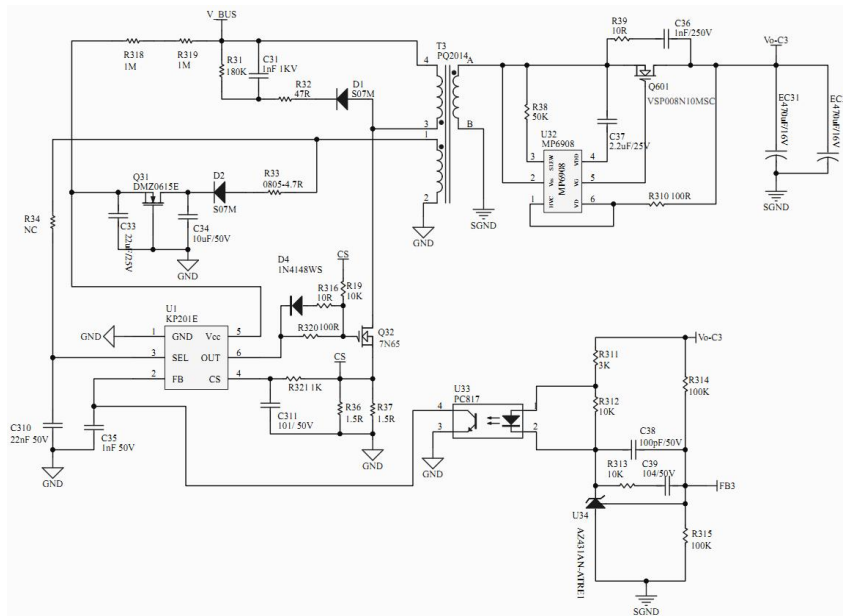

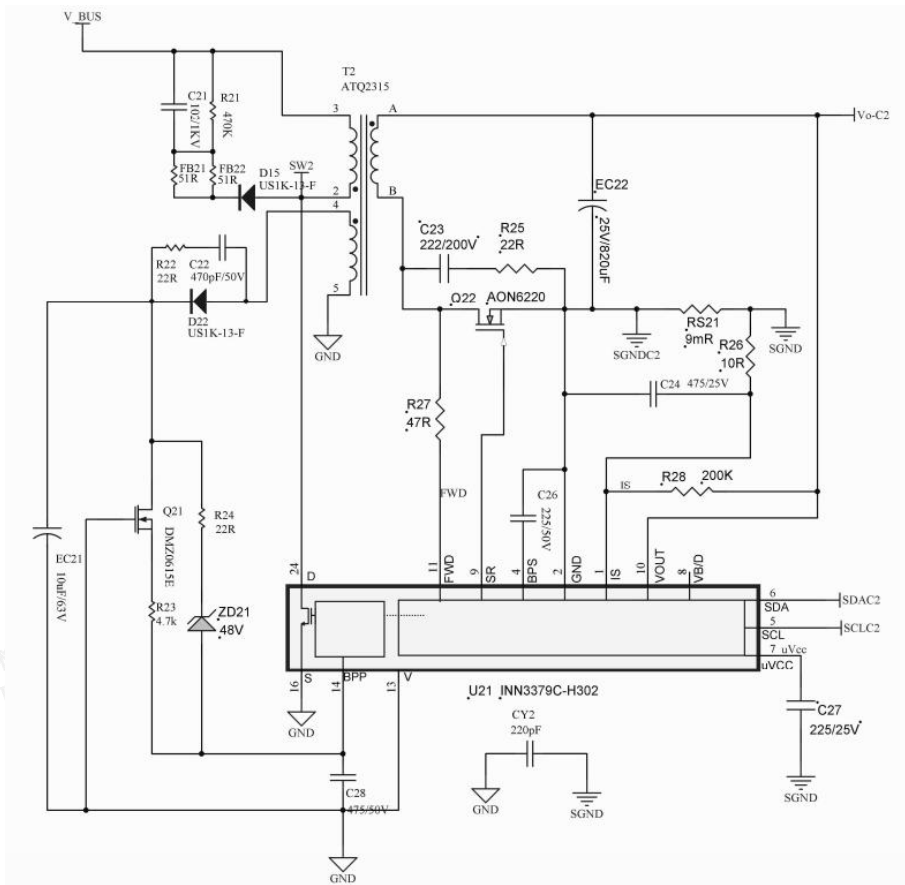
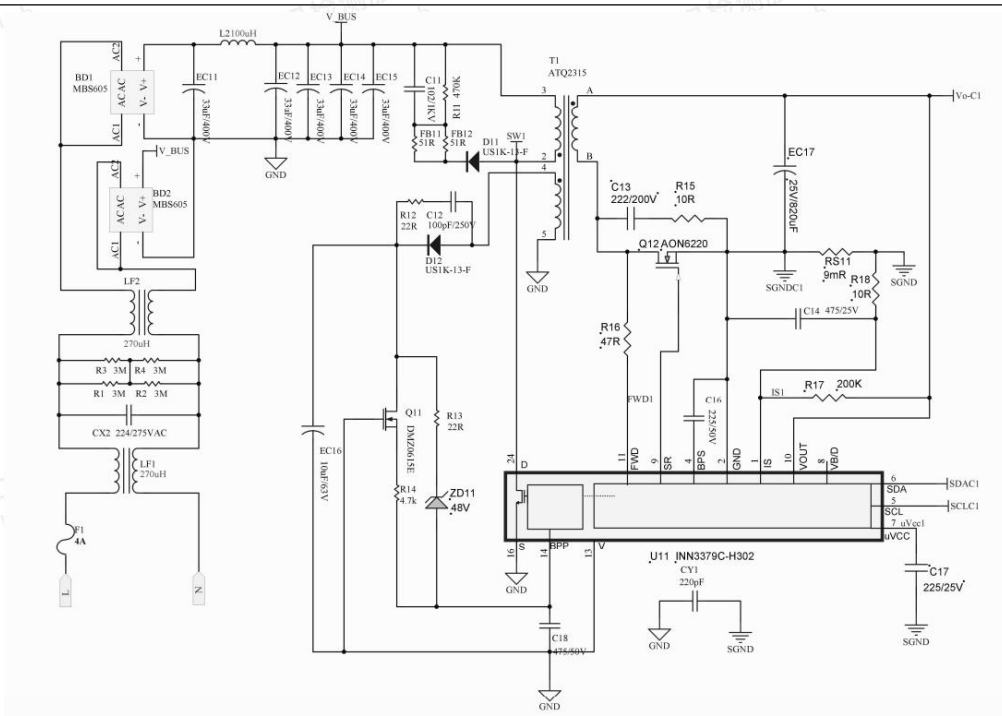



IEC 62368-1

Clause	Requirement + Test	Result - Remark	Verdict
4	GENERAL REQUIREMENTS		P
4.1.1	Acceptance of materials, components and subassemblies	See appended table 4.1.2	P
4.1.2	Use of components	Components which are certified to IEC and/or national standards are used correctly within their ratings. Components not covered by IEC standards are tested under the conditions present in the equipment. See also Annex G	P
4.1.3	Equipment design and construction	Evaluation of safeguards regarding limiting the outputs to fulfill ES1 and protection in regard to risk of spread of fire, mechanical and thermal burn injury considered.	P
4.1.4	Specified ambient temperature for outdoor use (°C) :	Indoor use only	N/A
4.1.5	Constructions and components not specifically covered		N/A
4.1.8	Liquids and liquid filled components (LFC)		N/A
4.1.15	Markings and instructions	(See Annex F)	P
4.4.3	Safeguard robustness		P
4.4.3.1	General		P
4.4.3.2	Steady force tests	(See Annex T.2, T.4)	P
4.4.3.3	Drop tests	(See Annex T.7)	P
4.4.3.4	Impact tests		N/A
4.4.3.5	Internal accessible safeguard tests	No such safeguard.	N/A
4.4.3.6	Glass impact tests	No such glass used.	N/A
4.4.3.7	Glass fixation tests		N/A
	Glass impact test (1J)		N/A
	Push/pull test (10 N)		N/A
4.4.3.8	Thermoplastic material tests	(See Annex T.8)	P
4.4.3.9	Air comprising a safeguard		P
4.4.3.10	Accessibility, glass, safeguard effectiveness		P
4.4.4	Displacement of a safeguard by an insulating liquid		N/A
4.4.5	Safety interlocks		N/A
4.5	Explosion		N/A
4.5.1	General		N/A
4.5.2	No explosion during normal/abnormal operating	No explosion	N/A



Shenzhen LCS Compliance Testing Laboratory Ltd.

Add: Room 101, 201, Building A and Room 301, Building C, Juji Industrial Park, Yabianxueziwei, Shajing Street, Bao'an District, Shenzhen, Guangdong, China

Tel: +(86) 0755-82591330 | E-mail: webmaster@lcs-cert.com | Web: www.lcs-cert.com

Scan code to check authenticity



IEC 62368-1			
Clause	Requirement + Test	Result - Remark	Verdict
	condition		
	No harm by explosion during single fault conditions		N/A
4.6	Fixing of conductors		P
	Fix conductors not to defeat a safeguard		P
	Compliance is checked by test..... :	10N test was applied to internal components.	P
4.7	Equipment for direct insertion into mains socket-outlets		P
4.7.2	Mains plug part complies with relevant standard... :	See attachment.	P
4.7.3	Torque (Nm)..... :	0.01	P
4.8	Equipment containing coin/button cell batteries		N/A
4.8.1	General	No coin/button cell batteries used.	N/A
4.8.2	Instructional safeguard..... :		N/A
4.8.3	Battery compartment door/cover construction		N/A
	Open torque test		N/A
4.8.4.2	Stress relief test		N/A
4.8.4.3	Battery replacement test		N/A
4.8.4.4	Drop test		N/A
4.8.4.5	Impact test		N/A
4.8.4.6	Crush test		N/A
4.8.5	Compliance		N/A
	30N force test with test probe		N/A
	20N force test with test hook		N/A
4.9	Likelihood of fire or shock due to entry of conductive object		P
4.10	Component requirements		N/A
4.10.1	Disconnect Device		N/A
4.10.2	Switches and relays		N/A

5	ELECTRICALLY-CAUSED INJURY		P
5.2	Classification and limits of electrical energy sources		P
5.2.2	ES1, ES2 and ES3 limits	(See appended table 5.2)	P
5.2.2.2	Steady-state voltage and current limits..... :	(See appended table 5.2)	P
5.2.2.3	Capacitance limits..... :	(See appended table 5.2)	P
5.2.2.4	Single pulse limits..... :	No such single pulses generated in the EUT or applied to it.	N/A
5.2.2.5	Limits for repetitive pulses..... :	No such repetitive pulses within the EUT	N/A



Shenzhen LCS Compliance Testing Laboratory Ltd.

Add: Room 101, 201, Building A and Room 301, Building C, Juji Industrial Park, Yabianxueziwei, Shajing Street, Bao'an District, Shenzhen, Guangdong, China

Tel: +(86) 0755-82591330 | E-mail: webmaster@lcs-cert.com | Web: www.lcs-cert.com

Scan code to check authenticity



IEC 62368-1			
Clause	Requirement + Test	Result - Remark	Verdict
5.2.2.6	Ringing signals	No such ringing signals within the EUT	N/A
5.2.2.7	Audio signals	No such audio signals	N/A
5.3	Protection against electrical energy sources		P
5.3.1	General Requirements for accessible parts to ordinary, instructed and skilled persons		P
5.3.1 a)	Accessible ES1/ES2 derived from ES2/ES3 circuits		P
5.3.1 b)	Skilled persons not unintentional contact ES3 bare conductors		N/A
5.3.2.1	Accessibility to electrical energy sources and safeguards		P
	Accessibility to outdoor equipment bare parts		N/A
5.3.2.2	Contact requirements	No opening of enclosure, no access with test probe to any ES3 circuit or parts.	P
	Test with test probe from Annex V		--
5.3.2.2 a)	Air gap – electric strength test potential (V)..... :		P
5.3.2.2 b)	Air gap – distance (mm) :		N/A
5.3.2.3	Compliance		N/A
5.3.2.4	Terminals for connecting stripped wire	No stripped wire used.	N/A
5.4	Insulation materials and requirements		P
5.4.1.2	Properties of insulating material		P
5.4.1.3	Material is non-hygroscopic		P
5.4.1.4	Maximum operating temperature for insulating materials..... :	(See appended table 5.4.1.4)	P
5.4.1.5	Pollution degrees..... :	PD2	P
☆5.4.1.5.2	Test for pollution degree 1 environment and for an insulating compound	Pollution degree 2 is applied. No insulating compound applied (however see 5.5.4)	N/A
5.4.1.5.3	Thermal cycling test		N/A
5.4.1.6	Insulation in transformers with varying dimensions	No such transformer within the EUT	N/A
5.4.1.7	Insulation in circuits generating starting pulses	No such starting pulses within the EUT	N/A
5.4.1.8	Determination of working voltage..... :	T1: 540Vpeak, 251Vrms T2: 472Vpeak, 247Vrms T3: 552Vpeak, 269Vrms	P
5.4.1.9	Insulating surfaces		P
5.4.1.10	Thermoplastic parts on which conductive metallic parts are directly mounted		P
5.4.1.10.2	Vicat test..... :		N/A



Shenzhen LCS Compliance Testing Laboratory Ltd.

Add: Room 101, 201, Building A and Room 301, Building C, Juji Industrial Park, Yabianxueziwei, Shajing Street, Bao'an District, Shenzhen, Guangdong, China

Tel: +(86) 0755-82591330 | E-mail: webmaster@lcs-cert.com | Web: www.lcs-cert.com

Scan code to check authenticity





IEC 62368-1			
Clause	Requirement + Test	Result - Remark	Verdict
5.4.1.10.3	Ball pressure test.....:	(See appended table 5.4.1.10.3)	P
5.4.2	Clearances		P
5.4.2.1	General requirements		P
	Clearances in circuits connected to AC Mains, Alternative method		P
5.4.2.2	Procedure 1 for determining clearance		N/A
	Temporary overvoltage		—
5.4.2.3	Procedure 2 for determining clearance	(See appended table 5.4.2.3)	P
5.4.2.3.2.2	a.c. mains transient voltage..... :	2500Vpk	—
5.4.2.3.2.3	d.c. mains transient voltage		—
5.4.2.3.2.4	External circuit transient voltage.....:		—
5.4.2.3.2.5	Transient voltage determined by measurement.....:		—
☆ 5.4.2.3.2.5	Transient voltage determined by measurement.....:		N/A
5.4.2.4	Determining the adequacy of a clearance using an electric strength test	(See appended table 5.4.2)	N/A
5.4.2.5	Multiplication factors for clearances and test voltages		P
5.4.2.6	Clearance measurement.....:	(See appended table 5.4.2)	P
5.4.3	Creepage distances		P
5.4.3.1	General		—
☆5.4.3.3	Material group.....:	IIIa&IIIb	P
5.4.4	Solid insulation		P
5.4.4.1	General requirements		P
5.4.4.2	Minimum distance through insulation	(See appended table 5.4.4.2)	P
5.4.4.3	Insulating compound forming solid insulation		N/A
5.4.4.4	Solid insulation in semiconductor devices		N/A
5.4.4.5	Insulating compound forming cemented joints		N/A
5.4.4.6	Thin sheet material	Insulation tape used for transformer	P
5.4.4.6.1	General requirements		P
5.4.4.6.2	Separable thin sheet material		P
	Number of layers (pcs)	2	P
5.4.4.6.3	Non-separable thin sheet material	No such insulation used within the EUT	N/A
	Number of layers (pcs)		N/A
5.4.4.6.4	Standard test procedure for non-separable thin sheet material.....:		N/A





IEC 62368-1			
Clause	Requirement + Test	Result - Remark	Verdict
5.4.4.6.5	Mandrel test		N/A
5.4.4.7	Solid insulation in wound components		P
5.4.4.9	Solid insulation at frequencies >30 kHz, E_P , K_R , d , V_{PW} (V)..... :	(See appended Table 5.4.4.9)	P
	Alternative by electric strength test, tested voltage (V), K_R :		N/A
5.4.5	Antenna terminal insulation		N/A
5.4.5.1	General		N/A
5.4.5.2	Voltage surge test		N/A
5.4.5.3	Insulation resistance (M Ω)..... :		N/A
	Electric strength test..... :		N/A
5.4.6	Insulation of internal wire as part of supplementary safeguard	No such insulation of internal wire as part of supplementary safeguard.	N/A
5.4.7	Tests for semiconductor components and for cemented joints		N/A
5.4.8	Humidity conditioning		P
	Relative humidity (%), temperature ($^{\circ}$ C), duration (h)..... :	95%, 25 $^{\circ}$ C, 48hrs	—
5.4.9	Electric strength test	(See appended table 5.4.9)	P
5.4.9.1	Test procedure for type test of solid insulation..... :		P
5.4.9.2	Test procedure for routine test		P
5.4.10	Safeguards against transient voltages from external circuits		N/A
5.4.10.1	Parts and circuits separated from external circuits		N/A
5.4.10.2	Test methods		N/A
5.4.10.2.1	General		N/A
☆ 5.4.10.2.2	Impulse test..... :		N/A
5.4.10.2.3	Steady-state test..... :		N/A
5.4.10.3	Verification for insulation breakdown for impulse test..... :		N/A
5.4.11	Separation between external circuits and earth	No such connections for external circuit applied within the EUT	N/A
5.4.11.1	Exceptions to separation between external circuits and earth	No such connections to external circuit as above.	N/A
5.4.11.2	Requirements		N/A
	SPDs bridge separation between external circuit and earth		N/A
	Rated operating voltage U_{Op} (V)..... :		—



Shenzhen LCS Compliance Testing Laboratory Ltd.

Add: Room 101, 201, Building A and Room 301, Building C, Juji Industrial Park, Yabianxueziwei, Shajing Street, Bao'an District, Shenzhen, Guangdong, China

Tel: +(86) 0755-82591330 | E-mail: webmaster@lcs-cert.com | Web: www.lcs-cert.com

Scan code to check authenticity



IEC 62368-1

Clause	Requirement + Test	Result - Remark	Verdict
	Nominal voltage U_{peak} (V).....:		—
	Max increase due to variation ΔU_{sp}:		—
	Max increase due to ageing ΔU_{sa}:		—
5.4.11.3	Test method and compliance.....:		N/A
5.4.12	Insulating liquid		N/A
5.4.12.1	General requirements		N/A
5.4.12.2	Electric strength of an insulating liquid.....:		N/A
5.4.12.3	Compatibility of an insulating liquid.....:		N/A
5.4.12.4	Container for insulating liquid.....:		N/A
5.5	Components as safeguards		P
5.5.1	General		P
5.5.2	Capacitors and RC units		P
5.5.2.1	General requirement		P
5.5.2.2	Safeguards against capacitor discharge after disconnection of a connector.....:	(See appended table 5.5.2.2)	P
5.5.3	Transformers		P
5.5.4	Optocouplers		P
5.5.5	Relays	No such component provided.	N/A
5.5.6	Resistors	No such component provided.	N/A
5.5.7	SPDs	No such component provided.	N/A
5.5.8	Insulation between the mains and an external circuit consisting of a coaxial cable.....:	No such external circuits.	N/A
5.5.9	Safeguards for socket-outlets in outdoor equipment		N/A
	RCD rated residual operating current (mA).....:		—
5.6	Protective conductor		N/A
5.6.2	Requirement for protective conductors		N/A
5.6.2.1	General requirements		N/A
5.6.2.2	Colour of insulation		N/A
5.6.3	Requirement for protective earthing conductors		N/A
	Protective earthing conductor size (mm ²).....:		—
	Protective earthing conductor serving as a reinforced safeguard		N/A
	Protective earthing conductor serving as a double safeguard		N/A
5.6.4	Requirements for protective bonding conductors		N/A
5.6.4.1	Protective bonding conductors		N/A
	Protective bonding conductor size (mm ²).....:		—
5.6.4.2	Protective current rating (A).....:		N/A



Shenzhen LCS Compliance Testing Laboratory Ltd.

Add: Room 101, 201, Building A and Room 301, Building C, Juji Industrial Park, Yabianxueziwei, Shajing Street, Bao'an District, Shenzhen, Guangdong, China

Tel: +(86) 0755-82591330 | E-mail: webmaster@lcs-cert.com | Web: www.lcs-cert.com

Scan code to check authenticity



IEC 62368-1			
Clause	Requirement + Test	Result - Remark	Verdict
5.6.5	Terminals for protective conductors		N/A
5.6.5.1	Terminal size for connecting protective earthing conductors (mm)..... :		N/A
	Terminal size for connecting protective bonding conductors (mm)..... :		N/A
5.6.5.2	Corrosion		N/A
5.6.6	Resistance of the protective bonding system		N/A
5.6.6.1	Requirements		N/A
5.6.6.2	Test Method..... :		N/A
5.6.6.3	Resistance (Ω) or voltage drop..... :		N/A
5.6.7	Reliable connection of a protective earthing conductor		N/A
5.6.8	Functional earthing		N/A
	Conductor size (mm^2)..... :		N/A
	Class II with functional earthing marking :		N/A
	Appliance inlet cl & cr (mm)..... :		N/A
5.7	Prospective touch voltage, touch current and protective conductor current		P
5.7.2	Measuring devices and networks		P
5.7.2.1	Measurement of touch current	(See appended table 5.2)	P
5.7.2.2	Measurement of voltage		N/A
5.7.3	Equipment set-up, supply connections and earth connections		N/A
5.7.4	Unearthed accessible parts..... :		N/A
5.7.5	Earthed accessible conductive parts..... :		N/A
5.7.6	Requirements when touch current exceeds ES2 limits		N/A
	Protective conductor current (mA)..... :		N/A
	Instructional Safeguard..... :		N/A
5.7.7	Prospective touch voltage and touch current associated with external circuits		N/A
5.7.7.1	Touch current from coaxial cables		N/A
5.7.7.2	Prospective touch voltage and touch current associated with paired conductor cables		N/A
5.7.8	Summation of touch currents from external circuits		N/A
	a) Equipment connected to earthed external circuits, current (mA)..... :		N/A
	b) Equipment connected to unearthed external circuits, current (mA)..... :		N/A
5.8	Backfeed safeguard in battery backed up supplies		N/A
	Mains terminal ES..... :		N/A



Shenzhen LCS Compliance Testing Laboratory Ltd.

Add: Room 101, 201, Building A and Room 301, Building C, Juji Industrial Park, Yabianxueziwei, Shajing Street, Bao'an District, Shenzhen, Guangdong, China

Tel: +(86) 0755-82591330 | E-mail: webmaster@lcs-cert.com | Web: www.lcs-cert.com

Scan code to check authenticity



IEC 62368-1			
Clause	Requirement + Test	Result - Remark	Verdict
	Air gap (mm)..... :		N/A

6	ELECTRICALLY- CAUSED FIRE		P
6.2	Classification of PS and PIS		P
6.2.2	Power source circuit classifications..... :	(See appended table 6.2.2)	P
6.2.3	Classification of potential ignition sources		P
6.2.3.1	Arcing PIS :		P
6.2.3.2	Resistive PIS :		P
6.3	Safeguards against fire under normal operating and abnormal operating conditions		P
6.3.1	No ignition and attainable temperature value less than 90 % defined by ISO 871 or less than 300 °C for unknown materials..... :	No ignition and no such temperature attained within the equipment. (See appended table 5.4.1.4, 6.3.2, 9.0, B.2.6)	P
	Combustible materials outside fire enclosure..... :		N/A
6.4	Safeguards against fire under single fault conditions		P
6.4.1	Safeguard method	Method by control of fire spread applied, Fire enclosure provided.	P
6.4.2	Reduction of the likelihood of ignition under single fault conditions in PS1 circuits		N/A
6.4.3	Reduction of the likelihood of ignition under single fault conditions in PS2 and PS3 circuits		N/A
6.4.3.1	Supplementary safeguards		N/A
6.4.3.2	Single Fault Conditions..... :		N/A
	Special conditions for temperature limited by fuse		N/A
6.4.4	Control of fire spread in PS1 circuits		N/A
6.4.5	Control of fire spread in PS2 circuits		P
6.4.5.2	Supplementary safeguards		P
6.4.6	Control of fire spread in PS3 circuits		P
6.4.7	Separation of combustible materials from a PIS		N/A
6.4.7.2	Separation by distance		N/A
6.4.7.3	Separation by a fire barrier		N/A
6.4.8	Fire enclosures and fire barriers		P
6.4.8.2	Fire enclosure and fire barrier material properties	V-0 fire enclosure used.	P
6.4.8.2.1	Requirements for a fire barrier	No fire barrier	N/A
6.4.8.2.2	Requirements for a fire enclosure		P
6.4.8.3	Constructional requirements for a fire enclosure and a fire barrier		N/A
6.4.8.3.1	Fire enclosure and fire barrier openings	No fire enclosure opening	N/A



Shenzhen LCS Compliance Testing Laboratory Ltd.

Add: Room 101, 201, Building A and Room 301, Building C, Juji Industrial Park, Yabianxueziwei, Shajing Street, Bao'an District, Shenzhen, Guangdong, China

Tel: +(86) 0755-82591330 | E-mail: webmaster@lcs-cert.com | Web: www.lcs-cert.com

Scan code to check authenticity



IEC 62368-1			
Clause	Requirement + Test	Result - Remark	Verdict
6.4.8.3.2	Fire barrier dimensions	No fire barrier	N/A
6.4.8.3.3	Top openings and properties		N/A
	Openings dimensions (mm)..... :		N/A
6.4.8.3.4	Bottom openings and properties		N/A
	Openings dimensions (mm)..... :		N/A
	Flammability tests for the bottom of a fire enclosure		N/A
	Instructional Safeguard..... :		N/A
6.4.8.3.5	Side openings and properties		N/A
	Openings dimensions (mm)..... :		N/A
6.4.8.3.6	Integrity of a fire enclosure, condition met: a), b) or c)..... :		N/A
6.4.8.4	Separation of a PIS from a fire enclosure and a fire barrier distance (mm) or flammability rating..... :	V-0 fire enclosure used.	P
6.4.9	Flammability of insulating liquid..... :		N/A
6.5	Internal and external wiring		P
6.5.1	General requirements		P
6.5.2	Requirements for interconnection to building wiring..... :		P
6.5.3	Internal wiring size (mm ²) for socket-outlets..... :		N/A
6.6	Safeguards against fire due to the connection to additional equipment		P
7	INJURY CAUSED BY HAZARDOUS SUBSTANCES		N/A
7.2	Reduction of exposure to hazardous substances		N/A
7.3	Ozone exposure		N/A
7.4	Use of personal safeguards or personal protective equipment (PPE)		N/A
	Personal safeguards and instructions..... :		—
7.5	Use of instructional safeguards and instructions		N/A
	Instructional safeguard (ISO 7010)..... :		—
7.6	Batteries and their protection circuits		N/A
8	MECHANICALLY-CAUSED INJURY		P
8.2	Mechanical energy source classifications		P
8.3	Safeguards against mechanical energy sources		N/A
8.4	Safeguards against parts with sharp edges and corners		P
8.4.1	Safeguards		N/A
	Instructional Safeguard..... :		N/A
8.4.2	Sharp edges or corners	MS1: Edges and corners of the enclosure are rounded.	P



Shenzhen LCS Compliance Testing Laboratory Ltd.

Add: Room 101, 201, Building A and Room 301, Building C, Juji Industrial Park, Yabianxueziwei, Shajing Street, Bao'an District, Shenzhen, Guangdong, China

Tel: +(86) 0755-82591330 | E-mail: webmaster@lcs-cert.com | Web: www.lcs-cert.com

Scan code to check authenticity





IEC 62368-1			
Clause	Requirement + Test	Result - Remark	Verdict
8.5	Safeguards against moving parts		N/A
8.5.1	Fingers, jewellery, clothing, hair, etc., contact with MS2 or MS3 parts	No moving parts	N/A
	MS2 or MS3 part required to be accessible for the function of the equipment		N/A
	Moving MS3 parts only accessible to skilled person		N/A
8.5.2	Instructional safeguard..... :		N/A
8.5.4	Special categories of equipment containing moving parts		N/A
☆8.5.4.1	General		N/A
8.5.4.2	Equipment containing work cells with MS3 parts		N/A
8.5.4.2.1	Protection of persons in the work cell		N/A
8.5.4.2.2	Access protection override		N/A
8.5.4.2.2.1	Override system		N/A
8.5.4.2.2.2	Visual indicator		N/A
8.5.4.2.3	Emergency stop system		N/A
	Maximum stopping distance from the point of activation (m)..... :		N/A
	Space between end point and nearest fixed mechanical part (mm)..... :		N/A
8.5.4.2.4	Endurance requirements		N/A
	Mechanical system subjected to 100 000 cycles of operation		N/A
	- Mechanical function check and visual inspection		N/A
	- Cable assembly..... :		N/A
8.5.4.3	Equipment having electromechanical device for destruction of media		N/A
8.5.4.3.1	Equipment safeguards		N/A
8.5.4.3.2	Instructional safeguards against moving parts..... :		N/A
8.5.4.3.3	Disconnection from the supply		N/A
8.5.4.3.4	Cut type and test force (N)..... :		N/A
8.5.4.3.5	Compliance		N/A
☆8.5.5	High pressure lamps		N/A
	Explosion test..... :		N/A
8.5.5.3	Glass particles dimensions (mm)..... :		N/A
8.6	Stability of equipment		N/A
8.6.1	General		N/A
	Instructional safeguard..... :		N/A



Shenzhen LCS Compliance Testing Laboratory Ltd.

Add: Room 101, 201, Building A and Room 301, Building C, Juji Industrial Park, Yabianxueziwei, Shajing Street, Bao'an District, Shenzhen, Guangdong, China

Tel: +(86) 0755-82591330 | E-mail: webmaster@lcs-cert.com | Web: www.lcs-cert.com

Scan code to check authenticity



IEC 62368-1			
Clause	Requirement + Test	Result - Remark	Verdict
8.6.2	Static stability		N/A
8.6.2.2	Static stability test.....:		N/A
8.6.2.3	Downward force test		N/A
8.6.3	Relocation stability		N/A
	Wheels diameter (mm).....:		—
	Tilt test		N/A
8.6.4	Glass slide test		N/A
8.6.5	Horizontal force test.....:		N/A
8.7	Equipment mounted to wall, ceiling or other structure		N/A
8.7.1	Mount means type.....:		N/A
8.7.2	Test methods		N/A
	Test 1, additional downwards force (N).....:		N/A
	Test 2, number of attachment points and test force (N).....:		N/A
	Test 3 Nominal diameter (mm) and applied torque (Nm).....:		N/A
8.8	Handles strength		N/A
8.8.1	General		N/A
8.8.2	Handle strength test		N/A
	Number of handles.....:		—
	Force applied (N).....:		—
8.9	Wheels or casters attachment requirements		N/A
8.9.2	Pull test		N/A
8.10	Carts, stands and similar carriers		N/A
8.10.1	General		N/A
8.10.2	Marking and instructions.....:		N/A
8.10.3	Cart, stand or carrier loading test		N/A
	Loading force applied (N).....:		N/A
8.10.4	Cart, stand or carrier impact test		N/A
8.10.5	Mechanical stability		N/A
	Force applied (N).....:		—
8.10.6	Thermoplastic temperature stability		N/A
8.11	Mounting means for slide-rail mounted equipment (SRME)		N/A
8.11.1	General		N/A
8.11.2	Requirements for slide rails		N/A
	Instructional Safeguard.....:		N/A
8.11.3	Mechanical strength test		N/A



Shenzhen LCS Compliance Testing Laboratory Ltd.

Add: Room 101, 201, Building A and Room 301, Building C, Juji Industrial Park, Yabianxueziwei, Shajing Street, Bao'an District, Shenzhen, Guangdong, China

Tel: +(86) 0755-82591330 | E-mail: webmaster@lcs-cert.com | Web: www.lcs-cert.com

Scan code to check authenticity



IEC 62368-1			
Clause	Requirement + Test	Result - Remark	Verdict
8.11.3.1	Downward force test, force (N) applied..... :		N/A
8.11.3.2	Lateral push force test		N/A
8.11.3.3	Integrity of slide rail end stops		N/A
8.11.4	Compliance		N/A
8.12	Telescoping or rod antennas		N/A
	Button/ball diameter (mm)..... :		—

9	THERMAL BURN INJURY		P
9.2	Thermal energy source classifications		P
9.3	Touch temperature limits		P
9.3.1	Touch temperatures of accessible parts..... :	Temperature of enclosure classed as TS1.	P
9.3.2	Test method and compliance		P
9.4	Safeguards against thermal energy sources		P
9.5	Requirements for safeguards		P
9.5.1	Equipment safeguard	Enclosure provided to limit the transfer of thermal energy of internal parts under normal operating conditions and abnormal operating conditions.	P
9.5.2	Instructional safeguard..... :		N/A
9.6	Requirements for wireless power transmitters		N/A
9.6.1	General		N/A
9.6.2	Specification of the foreign objects		N/A
9.6.3	Test method and compliance..... :		N/A

10	RADIATION		P
10.2	Radiation energy source classification		P
10.2.1	General classification	RS1: indicator LED	P
	Lasers..... :		—
	Lamps and lamp systems..... :		—
	Image projectors..... :		—
	X-Ray..... :		—
	Personal music player..... :		—
10.3	Safeguards against laser radiation		N/A
	The standard(s) equipment containing laser(s) comply..... :		N/A



Shenzhen LCS Compliance Testing Laboratory Ltd.

Add: Room 101, 201, Building A and Room 301, Building C, Juji Industrial Park, Yabianxueziwei, Shajing Street, Bao'an District, Shenzhen, Guangdong, China

Tel: +(86) 0755-82591330 | E-mail: webmaster@lcs-cert.com | Web: www.lcs-cert.com

Scan code to check authenticity



IEC 62368-1

Clause	Requirement + Test	Result - Remark	Verdict
10.4	Safeguards against optical radiation from lamps and lamp systems (including LED types)		N/A
10.4.1	General requirements		N/A
	Instructional safeguard provided for accessible radiation level needs to exceed		N/A
	Risk group marking and location..... :		N/A
	Information for safe operation and installation		N/A
10.4.2	Requirements for enclosures		N/A
	UV radiation exposure..... :		N/A
10.4.3	Instructional safeguard..... :		N/A
10.5	Safeguards against X-radiation		N/A
10.5.1	Requirements		N/A
	Instructional safeguard for skilled persons..... :		—
10.5.3	Maximum radiation (pA/kg)..... :		—
10.6	Safeguards against acoustic energy sources		N/A
10.6.1	General		N/A
10.6.2	Classification		N/A
	Acoustic output $L_{Aeq,T}$, dB(A)..... :		N/A
	Unweighted RMS output voltage (mV)..... :		N/A
	Digital output signal (dBFS)..... :		N/A
10.6.3	Requirements for dose-based systems		N/A
10.6.3.1	General requirements		N/A
10.6.3.2	Dose-based warning and automatic decrease		N/A
10.6.3.3	Exposure-based warning and requirements		N/A
	30 s integrated exposure level (MEL30)..... :		N/A
	Warning for MEL \geq 100 dB(A)..... :		N/A
10.6.4	Measurement methods		N/A
10.6.5	Protection of persons		N/A
	Instructional safeguards..... :		N/A
10.6.6	Requirements for listening devices (headphones, earphones, etc.)		N/A
10.6.6.1	Corded listening devices with analogue input		N/A
	Listening device input voltage (mV)..... :		N/A
10.6.6.2	Corded listening devices with digital input		N/A
	Max. acoustic output $L_{Aeq,T}$, dB(A)..... :		N/A
10.6.6.3	Cordless listening devices		N/A
	Max. acoustic output $L_{Aeq,T}$, dB(A)..... :		N/A





IEC 62368-1			
Clause	Requirement + Test	Result - Remark	Verdict
B	NORMAL OPERATING CONDITION TESTS, ABNORMAL OPERATING CONDITION TESTS AND SINGLE FAULT CONDITION TESTS		P
B.1	General		P
B.1.5	Temperature measurement conditions		P
B.2	Normal operating conditions		P
B.2.1	General requirements..... :	(See Test Item Particulars and appended test tables)	P
	Audio Amplifiers and equipment with audio amplifiers..... :	Not such equipment.	N/A
B.2.3	Supply voltage and tolerances	Rated voltage \pm 10%	P
B.2.5	Input test..... :	(See appended table B.2.5)	P
B.3	Simulated abnormal operating conditions		P
B.3.1	General	(See appended table B.3)	P
B.3.2	Covering of ventilation openings		N/A
	Instructional safeguard..... :		N/A
B.3.3	DC mains polarity test		N/A
B.3.4	Setting of voltage selector	No voltage selector was used.	N/A
B.3.5	Maximum load at output terminals		P
B.3.6	Reverse battery polarity	No battery within the EUT	N/A
B.3.7	Audio amplifier abnormal operating conditions		N/A
B.3.8	Safeguards functional during and after abnormal operating conditions..... :	All safeguards remained effective.	P
B.4	Simulated single fault conditions		P
B.4.1	General		P
B.4.2	Temperature controlling device		N/A
B.4.3	Blocked motor test		N/A
B.4.4	Functional insulation	See below.	P
B.4.4.1	Short circuit of clearances for functional insulation	(See appended table B.4)	P
B.4.4.2	Short circuit of creepage distances for functional insulation	(See appended table B.4)	P
B.4.4.3	Short circuit of functional insulation on coated printed boards	No coated printed boards used.	N/A
B.4.5	Short-circuit and interruption of electrodes in tubes and semiconductors	(See appended table B.4 for faults on electronic components)	P
B.4.6	Short circuit or disconnection of passive components	(See appended table B.4)	P



Shenzhen LCS Compliance Testing Laboratory Ltd.

Add: Room 101, 201, Building A and Room 301, Building C, Juji Industrial Park, Yabianxueziwei, Shajing Street, Bao'an District, Shenzhen, Guangdong, China

Tel: +(86) 0755-82591330 | E-mail: webmaster@lcs-cert.com | Web: www.lcs-cert.com

Scan code to check authenticity



IEC 62368-1			
Clause	Requirement + Test	Result - Remark	Verdict
B.4.7	Continuous operation of components	The EUT is continuous operating type and no such components intended for short time operation or intermittent operation	N/A
B.4.8	Compliance during and after single fault conditions	No change to circuits classified in 5.3.	P
B.4.9	Battery charging and discharging under single fault conditions	No battery involved in the EUT	N/A
C	UV RADIATION		N/A
C.1	Protection of materials in equipment from UV radiation		N/A
C.1.2	Requirements		N/A
C.1.3	Test method		N/A
C.2	UV light conditioning test		N/A
C.2.1	Test apparatus..... :		N/A
C.2.2	Mounting of test samples		N/A
C.2.3	Carbon-arc light-exposure test		N/A
C.2.4	Xenon-arc light-exposure test		N/A
D	TEST GENERATORS		N/A
D.1	Impulse test generators		N/A
D.2	Antenna interface test generator		N/A
D.3	Electronic pulse generator		N/A
E	TEST CONDITIONS FOR EQUIPMENT CONTAINING AUDIO AMPLIFIERS		N/A
E.1	Electrical energy source classification for audio signals		N/A
	Maximum non-clipped output power (W)..... :		—
	Rated load impedance (Ω)		—
	Open-circuit output voltage (V)..... :		—
	Instructional safeguard..... :		—
E.2	Audio amplifier normal operating conditions		N/A
	Audio signal source type..... :		—
	Audio output power (W)..... :		—
	Audio output voltage (V)..... :		—
	Rated load impedance (Ω)		—
	Requirements for temperature measurement		N/A
E.3	Audio amplifier abnormal operating conditions		N/A
F	EQUIPMENT MARKINGS, INSTRUCTIONS, AND INSTRUCTIONAL SAFEGUARDS		P
F.1	General		P



Shenzhen LCS Compliance Testing Laboratory Ltd.

Add: Room 101, 201, Building A and Room 301, Building C, Juji Industrial Park, Yabianxueziwei, Shajing Street, Bao'an District, Shenzhen, Guangdong, China

Tel: +(86) 0755-82591330 | E-mail: webmaster@lcs-cert.com | Web: www.lcs-cert.com

Scan code to check authenticity



IEC 62368-1			
Clause	Requirement + Test	Result - Remark	Verdict
	Language	English version provided and checked.	—
F.2	Letter symbols and graphical symbols		P
F.2.1	Letter symbols according to IEC60027-1	Letter symbols for quantities and units are complied with IEC 60027-1.	N/A
F.2.2	Graphic symbols according to IEC, ISO or manufacturer specific	Graphical symbols are complied with IEC 60417, ISO 3864-2, ISO 7000 or ISO 7010.	P
F.3	Equipment markings		P
F.3.1	Equipment marking locations	The required marking is located on the product is easily visible.	P
F.3.2	Equipment identification markings	See copy of marking plate.	P
F.3.2.1	Manufacturer identification	See copy of marking plate.	P
F.3.2.2	Model identification	See page 2 for details	P
F.3.3	Equipment rating markings	See the following details.	P
F.3.3.1	Equipment with direct connection to mains		P
F.3.3.2	Equipment without direct connection to mains		N/A
F.3.3.3	Nature of the supply voltage.....	See copy of marking plate.	—
F.3.3.4	Rated voltage.....	See copy of marking plate.	—
F.3.3.5	Rated frequency.....	See copy of marking plate.	—
F.3.3.6	Rated current or rated power.....	See copy of marking plate.	—
F.3.3.7	Equipment with multiple supply connections	Only one mains supply connection provided.	N/A
F.3.4	Voltage setting device	No voltage setting device.	N/A
F.3.5	Terminals and operating devices	See below.	P
F.3.5.1	Mains appliance outlet and socket-outlet markings	No such devices on the equipment	N/A
F.3.5.2	Switch position identification marking.....	No switch used.	N/A
F.3.5.3	Replacement fuse identification and rating markings	Fuse is located within the equipment and not replaceable by an ordinary person or an instructed person	P
	Instructional safeguards for neutral fuse.....	No such battery on the equipment.	N/A
F.3.5.4	Replacement battery identification marking.....		N/A
F.3.5.5	Neutral conductor terminal	See below.	N/A
F.3.5.6	Terminal marking location		N/A
F.3.6	Equipment markings related to equipment classification		P



Shenzhen LCS Compliance Testing Laboratory Ltd.

Add: Room 101, 201, Building A and Room 301, Building C, Juji Industrial Park, Yabianxueziwei, Shajing Street, Bao'an District, Shenzhen, Guangdong, China

Tel: +(86) 0755-82591330 | E-mail: webmaster@lcs-cert.com | Web: www.lcs-cert.com

Scan code to check authenticity



IEC 62368-1			
Clause	Requirement + Test	Result - Remark	Verdict
F.3.6.1	Class I equipment		N/A
F.3.6.1.1	Protective earthing conductor terminal.....:		N/A
F.3.6.1.2	Protective bonding conductor terminals		N/A
F.3.6.2	Equipment class marking..... :		N/A
F.3.6.3	Functional earthing terminal marking..... :		N/A
F.3.7	Equipment IP rating marking..... :	IPX0.	—
F.3.8	External power supply output marking..... :		N/A
F.3.9	Durability, legibility and permanence of marking	Marking is considered to be legible and easily discernible. See also the following details.	P
F.3.10	Test for permanence of markings	The label was subjected to the permanence of marking test. The label was rubbed with cloth soaked with water for 15 sec. And then again for 15 sec, with the cloth soaked with petroleum spirit. After this test there was no damage to the label. The marking on the label did not fade. There was no curling and lifting of the label edge. After each test, the marking remained legible.	P
F.4	Instructions		P
	a) Information prior to installation and initial use		P
	b) Equipment for use in locations where children not likely to be present		N/A
	c) Instructions for installation and interconnection		N/A
	d) Equipment intended for use only in restricted access area		N/A
	e) Equipment intended to be fastened in place		N/A
	f) Instructions for audio equipment terminals		N/A
	g) Protective earthing used as a safeguard		N/A
	h) Protective conductor current exceeding ES2 limits		N/A
	i) Graphic symbols used on equipment		P
	j) Permanently connected equipment not provided with all-pole mains switch		N/A
	Replaceable components or modules providing safeguard function		N/A
	Equipment containing insulating liquid		N/A
	Installation instructions for outdoor equipment		N/A



Shenzhen LCS Compliance Testing Laboratory Ltd.

Add: Room 101, 201, Building A and Room 301, Building C, Juji Industrial Park, Yabianxueziwei, Shajing Street, Bao'an District, Shenzhen, Guangdong, China

Tel: +(86) 0755-82591330 | E-mail: webmaster@lcs-cert.com | Web: www.lcs-cert.com

Scan code to check authenticity



IEC 62368-1			
Clause	Requirement + Test	Result - Remark	Verdict
F.5	Instructional safeguards		N/A
G	COMPONENTS		P
☆ G.1	Switches		N/A
G.1.1	General		N/A
G.1.2	Ratings, endurance, spacing, maximum load		N/A
G.1.3	Test method and compliance		N/A
☆ G.2	Relays		N/A
G.2.1	Requirements	No relay used.	N/A
G.2.2	Overload test		N/A
G.2.3	Relay controlling connectors supplying power to other equipment		N/A
G.2.4	Test method and compliance		N/A
☆ G.3	Protective devices		P
G.3.1	Thermal cut-offs	No thermal cut-offs provided within the equipment.	N/A
	Thermal cut-outs separately approved according to IEC 60730 with conditions indicated in a) & b)		N/A
	Thermal cut-outs tested as part of the equipment as indicated in c)		N/A
G.3.1.2	Test method and compliance		N/A
G.3.2	Thermal links		N/A
G.3.2.1	a) Thermal links tested separately according to IEC 60691 with specifics		N/A
	b) Thermal links tested as part of the equipment		N/A
G.3.2.2	Test method and compliance		N/A
G.3.3	PTC thermistors	No PTC thermistor used.	N/A
G.3.4	Overcurrent protection devices		P
G.3.5	Safeguards components not mentioned in G.3.1 to G.3.4		N/A
G.3.5.1	Non-resettable devices suitably rated and marking provided		N/A
G.3.5.2	Single faults conditions..... :		N/A
G.4	Connectors		N/A
G.4.1	Spacings		N/A
☆G.4.2	Mains connector configuration..... :		N/A
G.4.3	Plug is shaped that insertion into mains socket-outlets or appliance coupler is unlikely		N/A
G.5	Wound components		P



Shenzhen LCS Compliance Testing Laboratory Ltd.

Add: Room 101, 201, Building A and Room 301, Building C, Juji Industrial Park, Yabianxueziwei, Shajing Street, Bao'an District, Shenzhen, Guangdong, China

Tel: +(86) 0755-82591330 | E-mail: webmaster@lcs-cert.com | Web: www.lcs-cert.com

Scan code to check authenticity



IEC 62368-1			
Clause	Requirement + Test	Result - Remark	Verdict
G.5.1	Wire insulation in wound components	Approved TIW used for secondary winding of T1, T2, T3	P
G.5.1.2	Protection against mechanical stress	The tube is provided for primary and secondary winding of transformer to protect against mechanical stress.	P
☆G.5.2	Endurance test	Not applied for.	N/A
G.5.2.1	General test requirements		N/A
G.5.2.2	Heat run test		N/A
	Test time (days per cycle)..... :		—
	Test temperature (°C)..... :		—
G.5.2.3	Wound components supplied from the mains		N/A
G.5.2.4	No insulation breakdown		N/A
G.5.3	Transformers		P
G.5.3.1	Compliance method..... :		P
	Position..... :		P
	Method of protection..... :		P
G.5.3.2	Insulation	Primary windings and secondary windings are separated by Reinforced insulation	P
	Protection from displacement of windings..... :		—
G.5.3.3	Transformer overload tests		P
G.5.3.3.1	Test conditions		P
G.5.3.3.2	Winding temperatures		P
G.5.3.3.3	Winding temperatures - alternative test method		N/A
G.5.3.4	Transformers using FIW		N/A
G.5.3.4.1	General		N/A
	FIW wire nominal diameter..... :		—
G.5.3.4.2	Transformers with basic insulation only		N/A
G.5.3.4.3	Transformers with double insulation or reinforced insulation..... :		N/A
G.5.3.4.4	Transformers with FIW wound on metal or ferrite core		N/A
G.5.3.4.5	Thermal cycling test and compliance		N/A
G.5.3.4.6	Partial discharge test		N/A
G.5.3.4.7	Routine test		N/A
G.5.4	Motors		N/A



Shenzhen LCS Compliance Testing Laboratory Ltd.

Add: Room 101, 201, Building A and Room 301, Building C, Juji Industrial Park, Yabianxueziwei, Shajing Street, Bao'an District, Shenzhen, Guangdong, China

Tel: +(86) 0755-82591330 | E-mail: webmaster@lcs-cert.com | Web: www.lcs-cert.com

Scan code to check authenticity



IEC 62368-1			
Clause	Requirement + Test	Result - Remark	Verdict
G.5.4.1	General requirements		N/A
G.5.4.2	Motor overload test conditions		N/A
G.5.4.3	Running overload test		N/A
G.5.4.4.2	Locked-rotor overload test		N/A
	Test duration (days)		—
G.5.4.5	Running overload test for DC motors		N/A
G.5.4.5.2	Tested in the unit		N/A
G.5.4.5.3	Alternative method		N/A
G.5.4.6	Locked-rotor overload test for DC motors		N/A
G.5.4.6.2	Tested in the unit		N/A
	Maximum Temperature		N/A
G.5.4.6.3	Alternative method		N/A
G.5.4.7	Motors with capacitors		N/A
G.5.4.8	Three-phase motors		N/A
G.5.4.9	Series motors		N/A
	Operating voltage		—
G.6	Wire Insulation		P
G.6.1	General		P
G.6.2	Enamelled winding wire insulation		N/A
G.7	Mains supply cords		N/A
☆G.7.1	General requirements		N/A
	Type.....		—
G.7.2	Cross sectional area (mm ² or AWG).....		N/A
G.7.3	Cord anchorages and strain relief for non-detachable power supply cords		N/A
G.7.3.2	Cord strain relief		N/A
G.7.3.2.1	Requirements		N/A
	Strain relief test force (N).....		N/A
G.7.3.2.2	Strain relief mechanism failure		N/A
G.7.3.2.3	Cord sheath or jacket position, distance (mm).....		N/A
G.7.3.2.4	Strain relief and cord anchorage material		N/A
G.7.4	Cord Entry		N/A
G.7.5	Non-detachable cord bend protection		N/A
G.7.5.1	Requirements		N/A
G.7.5.2	Test method and compliance		N/A
	Overall diameter or minor overall dimension, <i>D</i> (mm).....		—



Shenzhen LCS Compliance Testing Laboratory Ltd.

Add: Room 101, 201, Building A and Room 301, Building C, Juji Industrial Park, Yabianxueziwei, Shajing Street, Bao'an District, Shenzhen, Guangdong, China

Tel: +(86) 0755-82591330 | E-mail: webmaster@lcs-cert.com | Web: www.lcs-cert.com

Scan code to check authenticity



IEC 62368-1			
Clause	Requirement + Test	Result - Remark	Verdict
	Radius of curvature after test (mm)..... :		—
G.7.6	Supply wiring space		N/A
G.7.6.1	General requirements		N/A
G.7.6.2	Stranded wire		N/A
G.7.6.2.1	Requirements		N/A
G.7.6.2.2	Test with 8 mm strand		N/A
☆G.8	Varistors		N/A
G.8.1	General requirements		N/A
G.8.2	Safeguards against fire		N/A
G.8.2.1	General		N/A
G.8.2.2	Varistor overload test		N/A
G.8.2.3	Temporary overvoltage test		N/A
☆G.9	Integrated circuit (IC) current limiters		N/A
G.9.1	Requirements		N/A
	IC limiter output current (max. 5A)..... :		—
	Manufacturers' defined drift :		—
G.9.2	Test Program		N/A
G.9.3	Compliance		N/A
☆G.10	Resistors		N/A
G.10.1	General		N/A
G.10.2	Conditioning		N/A
G.10.3	Resistor test		N/A
G.10.4	Voltage surge test		N/A
G.10.5	Impulse test		N/A
G.10.6	Overload test		N/A
☆G.11	Capacitors and RC units		P
G.11.1	General requirements	Certified Y1 capacitor used. Certified X1 capacitor used.	P
G.11.2	Conditioning of capacitors and RC units		N/A
G.11.3	Rules for selecting capacitors		N/A
☆G.12	Optocouplers		P
	Optocouplers comply with IEC 60747-5-5 with specifics		P
	Type test voltage $V_{ini,a}$:		—
	Routine test voltage, $V_{ini,b}$:		—
G.13	Printed boards		P



Shenzhen LCS Compliance Testing Laboratory Ltd.

Add: Room 101, 201, Building A and Room 301, Building C, Juji Industrial Park, Yabianxueziwei, Shajing Street, Bao'an District, Shenzhen, Guangdong, China

Tel: +(86) 0755-82591330 | E-mail: webmaster@lcs-cert.com | Web: www.lcs-cert.com

Scan code to check authenticity



IEC 62368-1			
Clause	Requirement + Test	Result - Remark	Verdict
G.13.1	General requirements	Certified PCB used	P
G.13.2	Uncoated printed boards		P
☆G.13.3	Coated printed boards	No coated printed board or multilayer board applied for within the equipment.	N/A
G.13.4	Insulation between conductors on the same inner surface		N/A
G.13.5	Insulation between conductors on different surfaces		N/A
	Distance through insulation..... :		N/A
	Number of insulation layers (pcs) :		—
☆G.13.6	Tests on coated printed boards		N/A
G.13.6.1	Sample preparation and preliminary inspection		N/A
G.13.6.2	Test method and compliance		N/A
☆G.14	Coating on components terminals		N/A
G.14.1	Requirements :	No coating on component terminals considered to affect creepage or clearances.	N/A
☆G.15	Pressurized liquid filled components		N/A
G.15.1	Requirements	No such device provided within the equipment.	N/A
G.15.2	Test methods and compliance		N/A
G.15.2.1	Hydrostatic pressure test		N/A
G.15.2.2	Creep resistance test		N/A
G.15.2.3	Tubing and fittings compatibility test		N/A
G.15.2.4	Vibration test		N/A
G.15.2.5	Thermal cycling test		N/A
G.15.2.6	Force test		N/A
G.15.3	Compliance		N/A
☆G.16	IC including capacitor discharge function (ICX)		N/A
G.16.1	Condition for fault tested is not required		N/A
	ICX with associated circuitry tested in equipment		N/A
	ICX tested separately		N/A
G.16.2	Tests		N/A
	Smallest capacitance and smallest resistance specified by ICX manufacturer for impulse test..... :		—
	Mains voltage that impulses to be superimposed on :		—
	Largest capacitance and smallest resistance for ICX tested by itself for 10000 cycles test..... :		—



Shenzhen LCS Compliance Testing Laboratory Ltd.

Add: Room 101, 201, Building A and Room 301, Building C, Juji Industrial Park, Yabianxueziwei, Shajing Street, Bao'an District, Shenzhen, Guangdong, China

Tel: +(86) 0755-82591330 | E-mail: webmaster@lcs-cert.com | Web: www.lcs-cert.com

Scan code to check authenticity



IEC 62368-1			
Clause	Requirement + Test	Result - Remark	Verdict
G.16.3	Capacitor discharge test..... :		N/A
H	CRITERIA FOR TELEPHONE RINGING SIGNALS		N/A
H.1	General		N/A
H.2	Method A		N/A
H.3	Method B		N/A
H.3.1	Ringling signal		N/A
H.3.1.1	Frequency (Hz) :		—
H.3.1.2	Voltage (V) :		—
H.3.1.3	Cadence; time (s) and voltage (V) :		—
H.3.1.4	Single fault current (mA):..... :		—
H.3.2	Tripping device and monitoring voltage		N/A
H.3.2.1	Conditions for use of a tripping device or a monitoring voltage		N/A
H.3.2.2	Tripping device		N/A
H.3.2.3	Monitoring voltage (V)..... :		N/A
J	INSULATED WINDING WIRES FOR USE WITHOUT INTERLEAVED INSULATION		P
J.1	General		P
	Winding wire insulation..... :		—
	Solid round winding wire, diameter (mm)..... :		N/A
	Solid square and rectangular (flatwise bending) winding wire, cross-sectional area (mm ²)..... :		N/A
J.2/J.3	Tests and Manufacturing		—
K	SAFETY INTERLOCKS		N/A
K.1	General requirements		N/A
	Instructional safeguard..... :		N/A
K.2	Components of safety interlock safeguard mechanism		N/A
K.3	Inadvertent change of operating mode		N/A
K.4	Interlock safeguard override		N/A
K.5	Fail-safe		N/A
K.5.1	Under single fault condition		N/A
K.6	Mechanically operated safety interlocks		N/A
K.6.1	Endurance requirement		N/A
K.6.2	Test method and compliance..... :		N/A
K.7	Interlock circuit isolation		N/A
K.7.1	Separation distance for contact gaps & interlock circuit elements		N/A



Shenzhen LCS Compliance Testing Laboratory Ltd.

Add: Room 101, 201, Building A and Room 301, Building C, Juji Industrial Park, Yabianxueziwei, Shajing Street, Bao'an District, Shenzhen, Guangdong, China

Tel: +(86) 0755-82591330 | E-mail: webmaster@lcs-cert.com | Web: www.lcs-cert.com

Scan code to check authenticity



IEC 62368-1

Clause	Requirement + Test	Result - Remark	Verdict
	In circuit connected to mains, separation distance for contact gaps (mm)..... :		N/A
	In circuit isolated from mains, separation distance for contact gaps (mm)..... :		N/A
	Electric strength test before and after the test of K.7.2..... :		N/A
☆K.7.2	Overload test, Current (A)..... :		N/A
☆K.7.3	Endurance test		N/A
K.7.4	Electric strength test		N/A
L	DISCONNECT DEVICES		P
L.1	General requirements		P
L.2	Permanently connected equipment		N/A
L.3	Parts that remain energized		N/A
L.4	Single-phase equipment		P
L.5	Three-phase equipment		N/A
L.6	Switches as disconnect devices		N/A
L.7	Plugs as disconnect devices		P
L.8	Multiple power sources		N/A
	Instructional safeguard..... :		N/A
M	EQUIPMENT CONTAINING BATTERIES AND THEIR PROTECTION CIRCUITS		N/A
M.1	General requirements		N/A
M.2	Safety of batteries and their cells		N/A
M.2.1	Batteries and their cells comply with relevant IEC standards..... :		N/A
M.3	Protection circuits for batteries provided within the equipment		N/A
M.3.1	Requirements		N/A
M.3.2	Test method		N/A
	Overcharging of a rechargeable battery		N/A
	Excessive discharging		N/A
	Unintentional charging of a non-rechargeable battery		N/A
	Reverse charging of a rechargeable battery		N/A
M.3.3	Compliance		N/A
M.4	Additional safeguards for equipment containing a portable secondary lithium battery		N/A
M.4.1	General		N/A
M.4.2	Charging safeguards		N/A
M.4.2.1	Requirements		N/A



Shenzhen LCS Compliance Testing Laboratory Ltd.

Add: Room 101, 201, Building A and Room 301, Building C, Juji Industrial Park, Yabianxueziwei, Shajing Street, Bao'an District, Shenzhen, Guangdong, China

Tel: +(86) 0755-82591330 | E-mail: webmaster@lcs-cert.com | Web: www.lcs-cert.com

Scan code to check authenticity



IEC 62368-1			
Clause	Requirement + Test	Result - Remark	Verdict
M.4.2.2	Compliance..... :		N/A
M.4.3	Fire enclosure..... :		N/A
M.4.4	Drop test of equipment containing a secondary lithium battery		N/A
M.4.4.2	Preparation and procedure for the drop test		N/A
M.4.4.3	Drop, Voltage on reference and dropped batteries (V); voltage difference during 24 h period (%):		N/A
M.4.4.4	Check of the charge/discharge function		N/A
M.4.4.5	Charge / discharge cycle test		N/A
M.4.4.6	Compliance		N/A
M.5	Risk of burn due to short-circuit during carrying		N/A
M.5.1	Requirement		N/A
M.5.2	Test method and compliance		N/A
M.6	Safeguards against short-circuits		N/A
M.6.1	External and internal faults		N/A
M.6.2	Compliance		N/A
☆ M.7	Risk of explosion from lead acid and NiCd batteries		N/A
M.7.1	Ventilation preventing explosive gas concentration		N/A
	Calculated hydrogen generation rate..... :		N/A
M.7.2	Test method and compliance		N/A
	Minimum air flow rate, Q (m ³ /h)..... :		N/A
M.7.3	Ventilation tests		N/A
M.7.3.1	General		N/A
M.7.3.2	Ventilation test – alternative 1		N/A
	Hydrogen gas concentration (%)..... :		N/A
M.7.3.3	Ventilation test – alternative 2		N/A
	Obtained hydrogen generation rate..... :		N/A
M.7.3.4	Ventilation test – alternative 3		N/A
	Hydrogen gas concentration (%)..... :		N/A
M.7.4	Marking..... :		N/A
☆ M.8	Protection against internal ignition from external spark sources of batteries with aqueous electrolyte		N/A
M.8.1	General		N/A
M.8.2	Test method		N/A
M.8.2.1	General		N/A
M.8.2.2	Estimation of hypothetical volume V _Z (m ³ /s)..... :		—
M.8.2.3	Correction factors..... :		—



Shenzhen LCS Compliance Testing Laboratory Ltd.

Add: Room 101, 201, Building A and Room 301, Building C, Juji Industrial Park, Yabianxueziwei, Shajing Street, Bao'an District, Shenzhen, Guangdong, China

Tel: +(86) 0755-82591330 | E-mail: webmaster@lcs-cert.com | Web: www.lcs-cert.com

Scan code to check authenticity



IEC 62368-1

Clause	Requirement + Test	Result - Remark	Verdict
M.8.2.4	Calculation of distance d (mm)		—
M.9	Preventing electrolyte spillage		N/A
M.9.1	Protection from electrolyte spillage		N/A
M.9.2	Tray for preventing electrolyte spillage		N/A
M.10	Instructions to prevent reasonably foreseeable misuse		N/A
	Instructional safeguard..... :		N/A
N	ELECTROCHEMICAL POTENTIALS		N/A
	Material(s) used..... :		—
O	MEASUREMENT OF CREEPAGE DISTANCES AND CLEARANCES		P
	Value of X (mm)..... :		—
P	SAFEGUARDS AGAINST CONDUCTIVE OBJECTS		N/A
P.1	General	No openings.	N/A
P.2	Safeguards against entry or consequences of entry of a foreign object		N/A
P.2.1	General		N/A
P.2.2	Safeguards against entry of a foreign object		N/A
	Location and Dimensions (mm)		—
P.2.3	Safeguards against the consequences of entry of a foreign object		N/A
P.2.3.1	Safeguard requirements		N/A
	The ES3 and PS3 keep-out volume in Figure P.3 not applicable to transportable equipment		N/A
	Transportable equipment with metalized plastic parts..... :		N/A
P.2.3.2	Consequence of entry test..... :		N/A
P.3	Safeguards against spillage of internal liquids		N/A
P.3.1	General		N/A
P.3.2	Determination of spillage consequences		N/A
P.3.3	Spillage safeguards		N/A
P.3.4	Compliance		N/A
☆ P.4	Metallized coatings and adhesives securing parts		N/A
P.4.1	General		N/A
P.4.2	Tests		N/A
	Conditioning, T_c (°C)..... :		—
	Duration (weeks)..... :		—
Q	CIRCUITS INTENDED FOR INTERCONNECTION WITH BUILDING WIRING		N/A
Q.1	Limited power sources		N/A
Q.1.1	Requirements		N/A



Shenzhen LCS Compliance Testing Laboratory Ltd.

Add: Room 101, 201, Building A and Room 301, Building C, Juji Industrial Park, Yabianxueziwei, Shajing Street, Bao'an District, Shenzhen, Guangdong, China

Tel: +(86) 0755-82591330 | E-mail: webmaster@lcs-cert.com | Web: www.lcs-cert.com

Scan code to check authenticity



IEC 62368-1			
Clause	Requirement + Test	Result - Remark	Verdict
	a) Inherently limited output		N/A
	b) Impedance limited output		N/A
	c) Regulating network limited output		N/A
	d) Overcurrent protective device limited output		N/A
	e) IC current limiter complying with G.9		N/A
Q.1.2	Test method and compliance.....:		N/A
	Current rating of overcurrent protective device (A):		N/A
Q.2	Test for external circuits – paired conductor cable		N/A
	Maximum output current (A):		N/A
	Current limiting method.....:		—
R	LIMITED SHORT CIRCUIT TEST		N/A
R.1	General		N/A
R.2	Test setup		N/A
	Overcurrent protective device for test.....:		—
R.3	Test method		N/A
	Cord/cable used for test.....:		—
R.4	Compliance		N/A
S	TESTS FOR RESISTANCE TO HEAT AND FIRE		N/A
S.1	Flammability test for fire enclosures and fire barrier materials of equipment where the steady state power does not exceed 4 000 W		N/A
	Samples, material.....:		—
	Wall thickness (mm).....:		—
	Conditioning (°C).....:		—
	Test flame according to IEC 60695-11-5 with conditions as set out		N/A
	- Material not consumed completely		N/A
	- Material extinguishes within 30s		N/A
	- No burning of layer or wrapping tissue		N/A
S.2	Flammability test for fire enclosure and fire barrier integrity		N/A
	Samples, material.....:		—
	Wall thickness (mm).....:		—
	Conditioning (°C).....:		—
S.3	Flammability test for the bottom of a fire enclosure		N/A
S.3.1	Mounting of samples		N/A
S.3.2	Test method and compliance		N/A



Shenzhen LCS Compliance Testing Laboratory Ltd.

Add: Room 101, 201, Building A and Room 301, Building C, Juji Industrial Park, Yabianxueziwei, Shajing Street, Bao'an District, Shenzhen, Guangdong, China

Tel: +(86) 0755-82591330 | E-mail: webmaster@lcs-cert.com | Web: www.lcs-cert.com

Scan code to check authenticity





IEC 62368-1

Clause	Requirement + Test	Result - Remark	Verdict
	Mounting of samples		—
	Wall thickness (mm).....		—
S.4	Flammability classification of materials		N/A
S.5	Flammability test for fire enclosure materials of equipment with a steady state power exceeding 4 000 W		N/A
	Samples, material.....		—
	Wall thickness (mm).....		—
	Conditioning (°C).....		—
T	MECHANICAL STRENGTH TESTS		P
T.1	General		P
T.2	Steady force test, 10 N	(See appended table T.2)	P
T.3	Steady force test, 30 N		N/A
T.4	Steady force test, 100 N	(See appended table T.4)	P
T.5	Steady force test, 250 N		N/A
T.6	Enclosure impact test		N/A
	Fall test		N/A
	Swing test		N/A
T.7	Drop test	(See appended table T.7)	P
T.8	Stress relief test.....	(See appended table T.8)	P
T.9	Glass Impact Test.....		N/A
☆ T.10	Glass fragmentation test		N/A
	Number of particles counted.....		N/A
T.11	Test for telescoping or rod antennas		N/A
	Torque value (Nm)		N/A
U	MECHANICAL STRENGTH OF CATHODE RAY TUBES (CRT) AND PROTECTION AGAINST THE EFFECTS OF IMPLOSION		N/A
U.1	General		N/A
	Instructional safeguard :		N/A
U.2	Test method and compliance for non-intrinsically protected CRTs		N/A
U.3	Protective screen		N/A
V	DETERMINATION OF ACCESSIBLE PARTS		P
V.1	Accessible parts of equipment		P
V.1.1	General		P
V.1.2	Surfaces and openings tested with jointed test probes		P
V.1.3	Openings tested with straight unjointed test probes		P



Shenzhen LCS Compliance Testing Laboratory Ltd.

Add: Room 101, 201, Building A and Room 301, Building C, Juji Industrial Park, Yabianxueziwei, Shajing Street, Bao'an District, Shenzhen, Guangdong, China

Tel: +(86) 0755-82591330 | E-mail: webmaster@lcs-cert.com | Web: www.lcs-cert.com

Scan code to check authenticity



IEC 62368-1			
Clause	Requirement + Test	Result - Remark	Verdict
V.1.4	Plugs, jacks, connectors tested with blunt probe		N/A
V.1.5	Slot openings tested with wedge probe		N/A
V.1.6	Terminals tested with rigid test wire		N/A
V.2	Accessible part criterion		P
X	ALTERNATIVE METHOD FOR DETERMINING CLEARANCES FOR INSULATION IN CIRCUITS CONNECTED TO AN AC MAINS NOT EXCEEDING 420 V PEAK (300 V RMS)		N/A
	Clearance..... :		N/A
Y	CONSTRUCTION REQUIREMENTS FOR OUTDOOR ENCLOSURES		N/A
Y.1	General		N/A
Y.2	Resistance to UV radiation		N/A
Y.3	Resistance to corrosion		N/A
Y.3	Resistance to corrosion		N/A
Y.3.1	Metallic parts of outdoor enclosures are resistant to effects of water-borne contaminants by..... :		N/A
Y.3.2	Test apparatus		N/A
Y.3.3	Water – saturated sulphur dioxide atmosphere		N/A
Y.3.4	Test procedure..... :		N/A
Y.3.5	Compliance		N/A
Y.4	Gaskets		N/A
Y.4.1	General		N/A
Y.4.2	Gasket tests		N/A
Y.4.3	Tensile strength and elongation tests		N/A
	Alternative test methods..... :		N/A
Y.4.4	Compression test		N/A
Y.4.5	Oil resistance		N/A
Y.4.6	Securing means		N/A
Y.5	Protection of equipment within an outdoor enclosure		N/A
Y.5.1	General		N/A
Y.5.2	Protection from moisture		N/A
	Relevant tests of IEC 60529 or Y.5.3..... :		N/A
Y.5.3	Water spray test		N/A
Y.5.4	Protection from plants and vermin		N/A
Y.5.5	Protection from excessive dust		N/A
Y.5.5.1	General		N/A
Y.5.5.2	IP5X equipment		N/A
Y.5.5.3	IP6X equipment		N/A
Y.6	Mechanical strength of enclosures		N/A



Shenzhen LCS Compliance Testing Laboratory Ltd.

Add: Room 101, 201, Building A and Room 301, Building C, Juji Industrial Park, Yabianxueziwei, Shajing Street, Bao'an District, Shenzhen, Guangdong, China

Tel: +(86) 0755-82591330 | E-mail: webmaster@lcs-cert.com | Web: www.lcs-cert.com

Scan code to check authenticity



IEC 62368-1			
Clause	Requirement + Test	Result - Remark	Verdict
Y.6.1	General		N/A
Y.6.2	Impact test..... :		N/A





5.2		TABLE: Classification of electrical energy sources					P
Supply Voltage	Location (e.g. circuit designation)	Test conditions	Parameters				ES Class
			U (V)	I (mA)	Type ¹⁾	Additional Info ²⁾	
264Vac	Primary circuits supplied by a.c. , mains supply	Normal	--	--	--	--	ES3 (declaration)
		Abnormal	--	--	--	--	
		Single fault	--	--	--	--	
264Vac	T1 Pin A-B	Normal	71.0Vpk/ 21.3Vrms	--	--	42.7kHz	ES2
		Abnormal	--	--	--	--	
		Single fault	--	--	--	--	
264Vac	T2 Pin A-B	Normal	36.4Vpk/ 11.5Vrms	--	--	53.8kHz	ES1
		Abnormal	--	--	--	--	
		Single fault	--	--	--	--	
264Vac	T3 Pin A-B	Normal	28.6Vpk/ 12.0Vrms	--	--	48.2kHz	ES1
		Abnormal	--	--	--	--	
		Single fault	--	--	--	--	
264Vac	Output "+" to "-"	Normal	20.00Vdc max	--	--	DC	ES1
		Abnormal	--	--	--	--	
		Single fault – Fuse opened (see table B.4 for details)	0	--	--	DC	
		Single fault – Shutdown (see table B.4 for details)	0	--	--	DC	
264Vac	Output "+/-" to earth	Normal	--	0.046m A rms	--	60Hz	ES1
		Abnormal	--	0.046m A rms	--	60Hz	
		Single fault – Fuse opened (see table B.4 for details)	--	0.046m A rms	--	60Hz	
		Single fault – Shutdown (see table B.4 for details)	--	0.046m A rms	--	60Hz	





264Vac	Plastic enclosure to earth	Normal	--	0.005 mApk	--	60Hz	ES1
		Abnormal	--	0.005 mApk	--	60Hz	
		Single fault – Fuse opened (see table B.4 for details)	--	0.01 mApk	--	60Hz	
		Single fault – Shutdown (see table B.4 for details)	--	0.005 mApk	--	60Hz	
Supplementary information: SC: short circuit.							

5.4.1.10.2	TABLE: Vicat softening temperature of thermoplastics				N/A
Method..... : ISO 306 / B50				—	
Object/ Part No./Material	Manufacturer/trademark	Thickness (mm)	T softening (°C)		
--	--	--	--		
Supplementary information:					

5.4.1.10.3	TABLE: Ball pressure test of thermoplastics				P
Allowed impression diameter (mm)..... : ≤ 2 mm				—	
Object/Part No./Material	Manufacturer/trademark	Thickness (mm)	Test temperature (°C)	Impression diameter (mm)	
Plug holder	See table 4.1.2	See table 4.1.2	125	1.1	
Supplementary information:					

5.4.2, 5.4.3	TABLE: Minimum Clearances/Creepage distance							P
Clearance (cl) and creepage distance (cr) at/of/between:	U _p (V)	U _{rms} (V)	Freq ¹⁾ (Hz)	Required cl (mm)	cl (mm)	E.S. ²⁾ (V)	Required cr (mm)	cr (mm)
Functional:								
L- N before fuse F1	420	250	0.06	1.5	2.6	--	2.5	3.6
Across fuse F1	420	250	0.06	1.5	2.9	--	2.5	2.9
Basic/ Supplementary:								
--	--	--	--	--	--	--	--	--
Reinforced:								
Primary live parts to enclosure outside	420	250	0.06	3.0	6.0	--	5.0	6.0





Primary trace to secondary trace	420	250	59.8	3.0	5.7	--	5.0	5.7
T1 primary winding to secondary winding	540	251	45.9	3.0	5.8	--	5.2	5.8
T1 core to secondary pin	540	251	45.9	3.0	6.0	--	5.2	6.0
T2 primary winding to secondary winding	472	247	52.1	3.0	5.5	--	5.0	5.5
T2 core to secondary pin	472	247	52.1	3.0	5.7	--	5.0	5.7
T3 primary winding to secondary winding	552	269	58.8	3.0	5.6	--	5.4	5.6
T3 core to secondary pin	552	269	58.8	3.0	5.8	--	5.4	5.8
CY1 primary pin to secondary pin	420	250	0.06	3.0	7.9	--	5.0	7.9
CY2 primary pin to secondary pin	420	250	0.06	3.0	8.0	--	5.0	8.0
U33 primary pin to secondary pin	420	250	0.06	3.0	7.6	--	5.0	7.6
Supplementary information:								
Note 1: Only for frequency above 30 kHz								
Note 2: See table 5.4.2.4 if this is based on electric strength test								
Note 3: Provide Material Group								

5.4.4.2	TABLE: Minimum distance through insulation				P
Distance through insulation (DTI) at/of	Peak voltage (V)	Insulation	Required DTI (mm)	Measured DTI (mm)	
Plastic enclosure	420	See table 4.1.2	0.4	See table 4.1.2	
Insulation tape	420	Polyethylene	See only 5.4.4.9	See only 5.4.4.9	
Bobbin (T1)	540	Phenolic	0.4	0.71	
Bobbin (T2)	472	Phenolic	0.4	0.71	
Bobbin (T3)	552	Phenolic	0.4	0.71	
Supplementary information:					



5.4.4.9	TABLE: Solid insulation at frequencies >30 kHz					P
Insulation material	E_P	Frequency (kHz)	K_R	Thickness d (mm)	Insulation	V_{PW} (Vpk)
Bobbin (T1)	17	45.9	0.71	0.71	Phenolic	540
Bobbin (T2)	17	52.1	0.71	0.71	Phenolic	472





Bobbin (T3)	17	58.8	0.71	0.71	Phenolic	552
Supplementary information:						

5.4.9	TABLE: Electric strength tests			P
Test voltage applied between:	Voltage shape (Surge, Impulse, AC, DC, etc.)	Test voltage (V)	Breakdown Yes / No	
Basic/supplementary:				
L to N (fuse F1 opened)	DC	2500V	No	
Reinforced:				
L /N to output terminal	DC	4000V	No	
Primary to enclosure with metal foil	DC	4000V	No	
T1: primary winding to secondary winding	DC	4000V	No	
T1: core to secondary winding	DC	4000V	No	
One layer insulation tape for T1	DC	4000V	No	
T2: primary winding to secondary winding	DC	4000V	No	
T2: core to secondary winding	DC	4000V	No	
One layer insulation tape for T2	DC	4000V	No	
T3: primary winding to secondary winding	DC	4000V	No	
T3: core to secondary winding	DC	4000V	No	
One layer insulation tape for T3	DC	4000V	No	
Supplementary information:				

5.5.2.2	TABLE: Stored discharge on capacitors				P
Location	Supply voltage (V)	Operating and fault condition ¹⁾	Switch position	Measured voltage (Vpk)	ES Class
264V, 60Hz	Phase to Neutral	N	No switch	4V	ES1
264V, 60Hz	Phase to Neutral	S (R1 opened)	No switch	8V	ES1
Supplementary information:					
X-capacitors installed for testing are: CX2=0.22uF					
<input checked="" type="checkbox"/> bleeding resistor rating: R1=R2==R3=R4=3MΩ					
[] ICX:					
1) Normal operating condition (e.g., normal operation, or open fuse), SC= short circuit, OC= open circuit					

5.6.6	TABLE: Resistance of protective conductors and terminations	N/A
-------	---	-----





Location	Test current (A)	Duration (min)	Voltage drop (V)	Resistance (Ω)
--	--	--	--	--
Supplementary information:				

5.7.4	TABLE: Unearthed accessible parts					N/A
Location	Operating and fault conditions	Supply Voltage (V)	Parameters			ES class
			Voltage (V_{rms} or V_{pk})	Current (A_{rms} or A_{pk})	Freq. (Hz)	
--	--	--	--	--	--	--
--	--	--	--	--	--	--
Supplementary information:						
Abbreviation: SC= short circuit; OC= open circuit						

5.7.5	TABLE: Earthed accessible conductive part			N/A
Supply voltage (V).....:				—
Phase(s)	[X] Single Phase; [] Three Phase: [] Delta [] Wye			
Power Distribution System	<input checked="" type="checkbox"/> TN <input type="checkbox"/> TT <input type="checkbox"/> IT			
Location	Fault Condition No in IEC 60990 clause 6.2.2	Touch current (mA)	Comment	
--	--	--	--	
Supplementary Information:				

5.8	TABLE: Backfeed safeguard in battery backed up supplies					N/A
Location	Supply voltage (V)	Operating and fault condition	Time (s)	Open-circuit voltage (V)	Touch current (A)	ES Class
--	--	--	--	--	--	--
Supplementary information:						
Abbreviation: SC= short circuit, OC= open circuit						

6.2.2	TABLE: Power source circuit classifications					P
Location	Operating and fault condition	Voltage (V)	Current (A)	Max. Power ¹⁾ (W)	Time (S)	PS class
Internal circuit	--	--	--	--	--	PS3 (declaration)
USB-C1 Output (5V)	Normal	5.19	3.75	17.82	5	PS1
USB-C1	Normal	9.20	3.79	31.12	5	PS2





Output (9V)						
USB-C1 Output (12V)	Normal	12.01	3.68	41.67	5	PS2
USB-C1 Output (15V)	Normal	15.00	3.74	52.83	5	PS2
USB-C1 Output (20V)	Normal	20.00	6.17	115.74	5	PS3
Output	U41 Pin 11-18 SC	0	0	0	3	PS1
USB-C3 Output (5V)	Normal	5.13	4.03	19.36	5	PS2
USB-C3 Output (9V)	Normal	9.20	2.67	24.06	5	PS2
USB-C3 Output (12V)	Normal	12.25	2.01	24.16	5	PS2
USB-C3 Output	U51 Pin 1-18 SC	0	0	0	3	PS1
USB-A Output (5V)	Normal	5.13	3.61	17.63	5	PS2
USB-A Output (9V)	Normal	9.20	3.57	20.54	5	PS2
USB-A Output (12V)	Normal	12.25	3.62	20.93	5	PS2
USB-A Output	C69 SC	0	0	0	3	PS1
Supplementary information:						
Abbreviation: SC= short circuit; OC=open circuit.						
1) Measured after 3 s for PS1 and measured after 5 s for PS2 and PS3.						
2) *: Unit shutdown immediately, no damage, no hazard.						

6.2.3.1	TABLE: Determination of Arcing PIS				P
Location	Open circuit voltage after 3 s (Vpk)	Measured r.m.s current (A)	Calculated value	Arcing PIS? Yes / No	
All primary circuits / parts	--	--	--	Yes (declaration)	
Supplementary information:					
An Arcing PIS requires a minimum of 50 V (peak) a.c. or d.c. An Arcing PIS is established when the product of the open circuit voltage (V_p) and normal operating condition rms current (I_{rms}) is greater than 15.					
All conductors and devices are considered as PIS.					

6.2.3.2	TABLE: Determination of resistive PIS			P
Location	Operating and fault condition	Dissipate power (W)		Resistive PIS? Yes / No
All primary circuits / parts	--	--		Yes (declaration)
Supplementary information:				
Abbreviation: SC= short circuit; OC= open circuit				





A combination of voltmeter, VA and ammeter IA may be used instead of a wattmeter.

If a separate voltmeter and ammeter are used, the product of (VA x IA) is used to determine Resistive PIS classification.

A Resistive PIS: (a) dissipates more than 15 W, measured after 30 s of normal operation, or (b) under single fault conditions has either a power exceeding 100 W measured immediately after the introduction of the fault if electronic circuits, regulators or PTC devices are used, or has an available power exceeding 15 W measured 30 s after introduction of the fault.

All conductors and devices are considered as PIS.

8.5.5	TABLE: High pressure lamp				N/A
Lamp manufacturer	Lamp type	Explosion method	Longest axis of glass particle (mm)	Particle found beyond 1 m Yes / No	
--	--	--	--	--	
Supplementary information:					

9.6	TABLE: Temperature measurements for wireless power transmitters							N/A
Supply voltage (V).....:								—
Max. transmit power of transmitter (W).....:								—
Foreign objects	w/o receiver and direct contact		with receiver and direct contact		with receiver and at distance of 2 mm		with receiver and at distance of 5 mm	
	Object (°C)	Ambient (°C)	Object (°C)	Ambient (°C)	Object (°C)	Ambient (°C)	Object (°C)	Ambient (°C)
--	--	--	--	--	--	--	--	--
Supplementary information:								

5.4.1.4, 9.3, B.1.5, B.2.6	TABLE: Temperature measurements				P
Supply voltage (V).....:	90V/ 60Hz		264V/ 50Hz		—
Ambient temperature during test T_{amb} (°C).....:	--		--		—
Maximum measured temperature T of part/at:	T (°C)				Allowed T_{max} (°C)
USB-C1 Output: 20VDC, 5A					
Position	Horizontal	Vertical	Horizontal	Vertical	--
Plug holder	44.4	45.7	39.4	39.9	Ref.
AC input wire	69.0	69.9	56.6	63.6	105
PCB near BD2	70.9	72.2	69.1	69.6	130
EC11 body	93.0	93.9	74.5	81.5	105





L2 winding	100.9	102.2	81.7	82.2	130		
EC13 body	97.2	98.1	89.9	96.9	105		
EC14 body	97.3	98.6	83.8	84.3	105		
T1 winding	103.1	104.0	95.9	102.9	110		
T1 core	99.2	100.5	89.5	90.0	110		
T2 winding	103.5	104.4	100.3	107.3	110		
T2 core	99.4	100.7	95.7	96.2	110		
T3 winding	104.1	105.0	99.3	106.3	110		
T3 core	100.5	101.8	93.6	94.1	110		
CY1 body	105.1	106.0	95.6	102.6	125		
PCB near U11	114.5	115.8	97.8	98.3	130		
PCB near Q32	109.5	110.4	94.3	101.3	130		
U33 body	107.0	108.3	92.1	92.6	110		
CY2 body	108.1	109.0	94.1	101.1	125		
PCB near U21	71.6	72.9	65.7	66.2	130		
Enclosure inside near T1 top	97.0	97.9	84.5	91.5	Ref.		
Enclosure inside near T1 Bottom	77.9	79.2	74.2	74.7	Ref.		
Enclosure outside near T1 top	73.5	74.4	65.8	72.8	77		
Enclosure outside near T1 Bottom	55.6	56.9	51.9	52.4	77		
Ambient	25.0	25.0	25.0	25.0	--		
Temperature T of winding:	t ₁ (°C)	R ₁ (Ω)	t ₂ (°C)	R ₂ (Ω)	T (°C)	Allowed T _{max} (°C)	Insulation class
--	--	--	--	--	--	--	B
Supplementary information:							
<p>Note 1: The apparatus was submitted and evaluated for maximum manufacturer's recommended ambient (T_{ma}) of 25°C.</p> <p>Note 2: The temperatures were measured under the worse case normal mode defined in clause B.2.1.</p> <p>Note 3. Temperature limits are calculated as follows: Winding components providing safety isolation: Class B → T_{max} = 120 - 10=110°C</p>							



Shenzhen LCS Compliance Testing Laboratory Ltd.

Add: Room 101, 201, Building A and Room 301, Building C, Juji Industrial Park, Yabianxueziwei, Shajing Street, Bao'an District, Shenzhen, Guangdong, China

Tel: +(86) 0755-82591330 | E-mail: webmaster@lcs-cert.com | Web: www.lcs-cert.com

Scan code to check authenticity



5.4.1.4, 9.3, B.1.5, B.2.6					TABLE: Temperature measurements		P	
Supply voltage (V).....			90V/ 60Hz		264V/ 50Hz		—	
Ambient temperature during test T_{amb} (°C).....			--		--		—	
Maximum measured temperature T of part/at:			T (°C)				Allowed T_{max} (°C)	
USB-C1+ USB-C2+ USB-C3+ USB-A: 90W								
Position			Horizontal	Vertical	Horizontal	Vertical	--	
Plug holder			42.6	42.3	39.4	38.9	Ref.	
AC input wire			63.2	63.3	55.1	54.8	105	
PCB near BD2			74.2	73.9	73.4	72.9	130	
EC11 body			81.4	81.5	69.2	68.9	105	
L2 winding			90.7	90.4	78.3	77.8	130	
EC13 body			95.8	95.9	86.2	85.9	105	
EC14 body			87.2	86.9	80.0	79.5	105	
T1 winding			93.4	93.5	89.5	89.2	110	
T1 core			88.7	88.4	85.2	84.7	110	
T2 winding			103.7	103.8	99.6	99.3	110	
T2 core			102.2	101.9	96.2	95.7	110	
T3 winding			95.2	95.3	88.7	88.4	110	
T3 core			91.8	91.5	85.0	84.5	110	
CY1 body			91.3	91.4	86.2	85.9	125	
PCB near U11			100.7	100.4	93.6	93.1	130	
PCB near Q32			101.4	101.5	95.3	95.0	130	
U33 body			96.0	95.7	88.3	87.8	110	
CY2 body			95.0	95.1	89.3	89.0	125	
PCB near U21			64.0	63.7	61.0	60.5	130	
Enclosure inside near T1 top			86.2	86.3	80.0	79.7	Ref.	
Enclosure inside near T1 Bottom			73.9	73.6	67.9	67.4	Ref.	
Enclosure outside near T1 top			65.6	65.7	61.9	61.6	77	
Enclosure outside near T1 Bottom			51.5	51.2	49.8	49.3	77	
Ambient			25.0	25.0	25.0	25.0	--	
Temperature T of winding:		t_1 (°C)	R_1 (Ω)	t_2 (°C)	R_2 (Ω)	T (°C)	Allowed T_{max} (°C)	Insulation class
--		--	--	--	--	--	--	B
Supplementary information:								
Note 1: The apparatus was submitted and evaluated for maximum manufacturer's recommended								





ambient (T_{ma}) of 25°C.

Note 2: The temperatures were measured under the worse case normal mode defined in clause B.2.1.

Note 3: Temperature limits are calculated as follows:

Winding components providing safety isolation:

Class B → T_{max} = 120 - 10 = 110°C

B.2.5	TABLE: Input test							P
U (V)	Hz	I (A)	I rated (A)	P (W)	P rated (W)	Fuse No	I fuse (A)	Condition/status
90V	50Hz	1.878	--	108.0	--	F1	1.878	USB-C1 Output: 20V $\overline{=}$ 5A
100V	50Hz	1.704	2.5	107.5	--	F1	1.704	
240V	50Hz	1.032	2.5	107.3	--	F1	1.032	
264V	50Hz	0.829	--	107.5	--	F1	0.829	
90V	60Hz	1.990	--	108.4	--	F1	1.990	
100V	60Hz	1.735	2.5	107.6	--	F1	1.735	
240V	60Hz	1.054	2.5	107.0	--	F1	1.054	
264V	60Hz	0.825	--	107.2	--	F1	0.825	
90V	50Hz	1.748	--	99.6	--	F1	1.748	USB-C1+ USB-C2+ USB-C3+ USB-A: 90W
100V	50Hz	1.645	2.5	99.2	--	F1	1.645	
240V	50Hz	0.979	2.5	99.2	--	F1	0.979	
264V	50Hz	0.753	--	98.5	--	F1	0.753	
90V	60Hz	1.829	--	99.4	--	F1	1.829	
100V	60Hz	1.698	2.5	98.8	--	F1	1.698	
240V	60Hz	0.910	2.5	98.2	--	F1	0.910	
264V	60Hz	0.724	--	98.3	--	F1	0.724	
90V	50Hz	1.690	--	93.4	--	F1	1.690	USB-C1+ USB-C3: 85W
100V	50Hz	1.587	2.5	93.0	--	F1	1.587	
240V	50Hz	0.984	2.5	92.6	--	F1	0.984	
264V	50Hz	0.783	--	92.5	--	F1	0.783	
90V	60Hz	1.711	--	93.6	--	F1	1.711	
100V	60Hz	1.607	2.5	93.1	--	F1	1.607	
240V	60Hz	0.947	2.5	92.7	--	F1	0.947	
264V	60Hz	0.773	--	92.9	--	F1	0.773	
90V	50Hz	1.675	--	91.1	--	F1	1.675	USB-C1+USB-A: 83W
100V	50Hz	1.634	2.5	90.8	--	F1	1.634	
240V	50Hz	0.940	2.5	89.8	--	F1	0.940	
264V	50Hz	0.747	--	90.4	--	F1	0.747	
90V	60Hz	1.756	--	91.0	--	F1	1.756	



Shenzhen LCS Compliance Testing Laboratory Ltd.

Add: Room 101, 201, Building A and Room 301, Building C, Juji Industrial Park, Yabianxueziwei, Shajing Street, Bao'an District, Shenzhen, Guangdong, China

Tel: +(86) 0755-82591330 | E-mail: webmaster@lcs-cert.com | Web: www.lcs-cert.com

Scan code to check authenticity



100V	60Hz	1.570	2.5	90.9	--	F1	1.570	USB-C1(PPS)+USB-C3+USB-A: 59W
240V	60Hz	0.737	2.5	90.3	--	F1	0.737	
264V	60Hz	0.656	--	90.5	--	F1	0.656	
90V	50Hz	1.394	--	65.4	--	F1	1.394	
100V	50Hz	1.312	2.5	65.2	--	F1	1.312	
240V	50Hz	0.710	2.5	65.1	--	F1	0.710	
264V	50Hz	0.562	--	65.3	--	F1	0.562	
90V	60Hz	1.272	--	65.7	--	F1	1.272	
100V	60Hz	1.139	2.5	65.3	--	F1	1.139	
240V	60Hz	0.558	2.5	65.6	--	F1	0.558	
264V	60Hz	0.503	--	65.7	--	F1	0.503	
Supplementary information:								
The maximum measured current under rated voltage did not exceed 110% of the rated current.								

B.3, B.4 TABLE: Abnormal operating and fault condition tests							P
Ambient temperature Tamb (°C) :					25°C, if not specified		—
Power source for EUT: Manufacturer, model/type, output rating :					--		—
Component No.	Condition	Supply voltage (V)	Test time	Fuse no.	Fuse current (A)	Observation	
TYPE-C1 Output (20V)	OL	264	4hrs 15 mins	F1	0.825→ 0.983→ 0.181→ 0.02	Max. load to 6.17A, when exceed it unit shut down, no hazardous, no damage. T1 winding: 112.3°C; T1 core: 105.6°C; T2 winding: 108.6°C; T2 core: 103.4°C; T3 winding: 107.3°C; T3 core: 101.5°C; Enclosure outside near T1 Top: 75.6°C; Enclosure outside near T1 Bottom: 59.8°C; Ambient: 25.0°C	
BD1 pin 1-2	SC	264	1s	F1	0	Fuse opened, no hazardous.	
BD2 pin 1-2	SC	264	1s	F1	0	Fuse opened, no hazardous.	
EC11	SC	264	1s	F1	0	Fuse opened, no hazardous.	
U1 pin 1-5	SC	264	1s	F1	0	Fuse opened, no hazardous.	
Q11 pin S-D	SC	264	1s	F1	0	Fuse opened, Q1 damaged, no hazardous.	



Shenzhen LCS Compliance Testing Laboratory Ltd.

Add: Room 101, 201, Building A and Room 301, Building C, Juji Industrial Park, Yabianxueziwei, Shajing Street, Bao'an District, Shenzhen, Guangdong, China

Tel: +(86) 0755-82591330 | E-mail: webmaster@lcs-cert.com | Web: www.lcs-cert.com

Scan code to check authenticity



Q11 pin G-D	SC	264	1s	F1	0	Fuse opened, Q1 damaged, no hazardous.
Q11 pin G-S	SC	264	10mins	F1	0.02	Unit shut down, no damage, no hazardous.
T1 pin 1-2	SC	264	10mins	F1	0.02	Unit shut down, no damage, no hazardous.
T1 pin 4-5	SC	264	10mins	F1	0.02	Unit shut down, no damage, no hazardous.
T1 pin A-B	SC	264	10mins	F1	0.02	Unit shut down, no damage, no hazardous.
T2 pin 1-2	SC	264	10mins	F1	0.02	Unit shut down, no damage, no hazardous.
T2 pin 4-5	SC	264	10mins	F1	0.02	Unit shut down, no damage, no hazardous.
T2 pin A-B	SC	264	10mins	F1	0.02	Unit shut down, no damage, no hazardous.
T3 pin 1-2	SC	264	10mins	F1	0.02	Unit shut down, no damage, no hazardous.
T3 pin 4-5	SC	264	10mins	F1	0.02	Unit shut down, no damage, no hazardous.
T3 pin A-B	SC	264	10mins	F1	0.02	Unit shut down, no damage, no hazardous.
U33 pin 1-2	SC	264	10mins	F1	0.02	Unit shut down, no damage, no hazardous.
U33 pin 3-4	SC	264	10mins	F1	0.02	Unit shut down, no damage, no hazardous.
U33 pin 1	OC	264	10mins	F1	0.02	Unit shut down, no damage, no hazardous.
U33 pin 3	OC	264	10mins	F1	0.02	Unit shut down, no damage, no hazardous.
U61 pin 1-18	SC	264	10mins	F1	0.02	Unit shut down, no damage, no hazardous.
C69	SC	264	10mins	F1	0.02	Unit shut down, no damage, no hazardous.
USB-C1 Output	SC	264	10mins	F1	0.02	Unit shut down, no damage, no hazardous.
USB-C2 Output	SC	264	10mins	F1	0.02	Unit shut down, no damage, no hazardous.
USB-C3 Output	SC	264	10mins	F1	0.02	Unit shut down, no damage, no hazardous.
USB-A Output	SC	264	10mins	F1	0.02	Unit shut down, no damage, no hazardous.

Supplementary information:

- 1) SC: Short Circuit. OC: Open Circuit. OL: Overload
- 2) The test result shown all safeguards remained effective and didn't lead to a single fault condition during abnormal operating condition; In addition all safeguards complied with applicable requirements in this standard after restoration of normal operating conditions.





3) The test result showed no Class 1 or 2 energy source become Class 3 level during and after single fault condition.

M.3	TABLE: Protection circuits for batteries provided within the equipment						N/A
Is it possible to install the battery in a reverse polarity position?.....:							—
Equipment Specification	Charging						
	Voltage (V)			Current (A)			
	--			--			
Manufacturer/type	Battery specification						
	Non-rechargeable batteries			Rechargeable batteries			
	Discharging current (A)	Unintentional charging current (A)	Charging		Discharging current (A)	Reverse charging current (A)	
			Voltage (V)	Current (A)			
	--	--	--	--	--	--	
Note: The tests of M.3.2 are applicable only when above appropriate data is not available.							
Specified battery temperature (°C).....:							
Component No.	Fault condition	Charge/discharge mode	Test time	Temp. (°C)	Current (A)	Voltage (V)	Observation
--	--	--	--	--	--	--	--
Supplementary information:							
Abbreviation: SC= short circuit; OC= open circuit NL= no chemical leakage; NS= no spillage of liquid; NE= no explosion; NF= no emission of flame or expulsion of molten metal.							

M.4.2	TABLE: Charging safeguards for equipment containing a secondary lithium battery					N/A
Maximum specified charging voltage (V).....:						—
Maximum specified charging current (A)						—
Highest specified charging temperature (°C)						
Lowest specified charging temperature (°C)						
Battery manufacturer/type	Operating and fault condition	Measurement			Observation	
		Charging voltage (V)	Charging current (A)	Temp. (°C)		
--	--	--	--	--	--	
Supplementary information:						
Abbreviation: SC= short circuit; OC= open circuit; MSCV= maximum specified charging voltage; MSCC= maximum specified charging current; HSCT= highest specified charging temperature; LSCT= lowest specified charging temperature						

Q.1	TABLE: Circuits intended for interconnection with building wiring (LPS)					N/A	
Output Circuit	Condition	U _{oc} (V)	Time (s)	I _{sc} (A)		S (VA)	
				Meas.	Limit	Meas.	Limit





--	--	--	--	--	--	--	--
--	--	--	--	--	--	--	--

Supplementary Information:

SC: Short Circuit,

*: Unit shut down immediately, recoverable, no hazard.

T.2, T.3, T.4, T.5	TABLE: Steady force test						P
Part/Location	Material	Thickness (mm)	Probe	Force (N)	Test Duration (s)	Observation	
Enclosure	Plastic	Min.1.5	--	100	5	No damaged, no hazardous.	
Internal parts	--	--	--	10	5	No damaged, no hazardous.	
Supplementary information:							

T.6, T.9	TABLE: Impact test					N/A
Location/part	Material	Thickness (mm)	Height (mm)	Observation		
--	--	--	--	--		
Supplementary information:						

T.7	TABLE: Drop test				P
Location/part	Material	Thickness (mm)	Height (mm)	Observation	
Enclosure	Plastic	Min.1.5	1000	No damaged, no hazardous.	
Supplementary information:					

T.8	TABLE: Stress relief test					P
Location/Part	Material	Thickness (mm)	Oven Temperature (°C)	Duration (h)	Observation	
Enclosure	Plastic	Min.1.5	71	7	No damaged, no hazardous.	
Supplementary information:						



Shenzhen LCS Compliance Testing Laboratory Ltd.

Add: Room 101, 201, Building A and Room 301, Building C, Juji Industrial Park, Yabianxueziwei, Shajing Street, Bao'an District, Shenzhen, Guangdong, China

Tel: +(86) 0755-82591330 | E-mail: webmaster@lcs-cert.com | Web: www.lcs-cert.com

Scan code to check authenticity



X	TABLE: Alternative method for determining minimum clearances distances			N/A
Clearance distanced between:	Peak of working voltage (V)	Required cl (mm)	Measured cl (mm)	
--	--	--	--	
Supplementary information:				





4.1.2	TABLE: List of critical components				P
Object/part No.	Manufacturer / trademark	Type/model	Technical data	Standard (Edition /	Mark(s) of conformity ¹⁾
Plastic enclosure and Plug holder	Sabic Innovative Plastics US L L C	EXL9330(GG)(X)(f1)(B1)(IP)	Min. V-0, 110°C, min. 1.5mm thickness	UL 94 UL 746	UL E121562
(Alternative)	Sabic Innovative Plastics US L L C	940(f1)	Min. V-0, 120°C, min. 1.5mm thickness	UL 94 UL 746	UL E121562
Primary lead wire	Interchangeable	Interchangeable	VW-1, min. 300V, min.24AWG, min. 105°C	UL 758	UL
(Alternative)	Interchangeable	Interchangeable	Min. 24AWG, min. 105°C, min. 300V, VW-1	UL 758	UL
PCB	Fujian Milky-way Technology Co Ltd	MW-R4	V-0, 130°C	UL 796	UL E168066
(Alternative)	Interchangeable	Interchangeable	V-0 or better, 130°C	UL 796	UL
Current fuse (F1)	Dongguan Reomax Electronics Technology Co Ltd	MTS	T5A, 250Vac	IEC/EN 60127-1, IEC/EN 60127-3, UL 248-1, UL 248-14	VDE 40039420 UL E340427
(Alternative)	Dongguan Anlu Electronics Technology Co. Ltd.	AMT	T5A, 250Vac	IEC/EN 60127-1, IEC/EN 60127-3, UL 248-1, UL 248-14	VDE 40047322 UL E365174
Bridge Y-capacitor	Sichuan Teruixiang Technology International Co Ltd	TRX	Max. 1000pF, min. 250 V, min 125 °C. Y1 type	IEC/EN 60384-14	CB
(Alternative)	Shenzhen Teruixiang Electronic Co, Ltd.	TY-Series	Max. 1000pF, min. 250 V, min 125 °C. Y1 type	IEC/EN 60384-14	VDE 40031733
(Alternative)	Anshan Keifat Electronic Ceramic Technical Co Ltd	CT7	Max. 1000pF, min. 250 V, min 125 °C. Y1 type	IEC/EN 60384-14	VDE 40011817



Shenzhen LCS Compliance Testing Laboratory Ltd.

Add: Room 101, 201, Building A and Room 301, Building C, Juji Industrial Park, Yabianxueziwei, Shajing Street, Bao'an District, Shenzhen, Guangdong, China

Tel: +(86) 0755-82591330 | E-mail: webmaster@lcs-cert.com | Web: www.lcs-cert.com

Scan code to check authenticity



Optocoupler (U33)	Shenzhen Orient Components Co Ltd	OR-1008	di ≥ 0.4mm, ext. dcr ≥ 8.0mm, min.110°C	IEC/EN 60747-5-5,	VDE 40029733
(Alternative)	Lite-On Technology Corporation	LTV-1008	Dti = 0.4mm, Ext. = 8.0mm, 110°C	IEC/EN 60747-5-5,	VDE 138213
Transformer (T1, T2)	Shenzhen (Baiwei) Electronics Technology Co., Ltd	ATQ23.7-P310	Class B	IEC/EN 62368-1	Test with appliance
- Bobbin	Chang Chun Plastics Co Ltd	T375J	Phenolic, V-0, 150°C, min. 0.71mm thick	UL 94	UL E59481
- Magnet wire	SHANTOU SHENGANG ELECTRICAL INDUSTRIAL CO	xUEW/130, QA-x/130	Min. 130°C	UL 1446	UL E239508
(Alternative)	Interchangeable	Interchangeable	130°C Polyurethane	UL 1446	UL
- Triple insulation wire used in secondary	Shenzhen Kaizhong Hedong New Materials Co Ltd	TIW-B	130°C	IEC/EN 62368-1	VDE 40038861
- Tube	Dongguan Ling Free Hardware Plastics Product Co Ltd	LING FREE PTF TUBE	600V, 200°C, VW-1	UL 224	UL E352366
- Insulation tape	Jingjiang Yahua Pressure Sensitive Glue Co Ltd	CT	130°C	UL 510A	UL E165111
-Varnish	Zhuhai Changxian New Materials Technology Co Ltd	E962	Min. 130°C	UL1446	UL E335405
Transformer (T3)	Shenzhen (Baiwei) Electronics Technology Co., Ltd	PQ2014-P310	Class B	IEC/EN 62368-1	Test with appliance
- Bobbin	SHANTOU SHENGANG ELECTRICAL	xUEW/130, QA-x/130	Min. 130°C	UL 1446	UL E239508



Shenzhen LCS Compliance Testing Laboratory Ltd.

Add: Room 101, 201, Building A and Room 301, Building C, Juji Industrial Park, Yabianxueziwei, Shajing Street, Bao'an District, Shenzhen, Guangdong, China

Tel: +(86) 0755-82591330 | E-mail: webmaster@lcs-cert.com | Web: www.lcs-cert.com

Scan code to check authenticity



- Magnet wire	SHANTOU SHENGANG ELECTRICAL INDUSTRIAL CO LTD	xUEW/130, QA-x/130	Min. 130°C	UL 1446	UL E239508
(Alternative)	Interchangeable	Interchangeable	130°C Polyurethane	UL 1446	UL
- Triple insulation wire used in secondary	Shenzhen Kaizhong Hedong New Materials Co Ltd	TIW-B	130°C	IEC/EN 62368-1	VDE 40038861
- Tube	Dongguan Ling Free Hardware Plastics Product Co Ltd	LING FREE PTF TUBE	600V, 200°C, VW-1	UL 224	UL E352366
- Insulation tape	Jingjiang Yahua Pressure Sensitive Glue Co Ltd	CT	130°C	UL 510A	UL E165111
-Varnish	Zhuhai Changxian New Materials Technology Co Ltd	E962	Min. 130°C	UL1446	UL E335405
Insulation sheet	Sichuan Dongfang Insulating Material Co., Ltd.	DFR3732A(d)	Min. V-0, Min. 110°C, Min. 0.43mm thickness	UL 94 UL 746	UL E199019
Thermal conductive silicone	Guangdong Haoming Organic Silicon Material Co Ltd	HM-9160	V-0, 105°C	UL94 UL 746	UL E318202
Supplementary information: 1) Provided evidence ensures the agreed level of compliance. See OD-2039.					



Shenzhen LCS Compliance Testing Laboratory Ltd.

Add: Room 101, 201, Building A and Room 301, Building C, Juji Industrial Park, Yabianxueziwei, Shajing Street, Bao'an District, Shenzhen, Guangdong, China

Tel: +(86) 0755-82591330 | E-mail: webmaster@lcs-cert.com | Web: www.lcs-cert.com

Scan code to check authenticity



Attachment No.1

IEC62368_1E - ATTACHMENT			
Clause	Requirement + Test	Result - Remark	Verdict
ATTACHMENT TO TEST REPORT IEC 62368-1 BRITAIN GROUP DIFFERENCES AND NATIONAL DIFFERENCES (Audio/video, information and communication technology equipment - Part 1: Safety requirements)			
Differences according to.....: BS EN IEC 62368-1:2020+A11:2020			
Attachment Form No.....: EU_GD_IEC62368_1E			
Attachment Originator.....: UL(Demko)			
Master Attachment.....: 2021-02-04			
Copyright © 2021 IEC System for Conformity Testing and Certification of Electrical Equipment (IECEE), Geneva, Switzerland. All rights reserved.			
	CENELEC COMMON MODIFICATIONS (EN)		P
	Clause numbers in the cells that are shaded light grey are clause references in EN IEC 62368-1:2020+A11:2020. All other clause numbers in that column, except for those in the paragraph below, refers to IEC 62368-1:2018. Clauses, subclauses, notes, tables, figures and annexes which are additional to those in IEC 62368-1:2018 are prefixed "Z".		P
	Add the following annexes: Annex ZA (normative) Normative references to international publications with their corresponding European publications Annex ZB (normative) Special national conditions Annex ZC (informative) A-deviations Annex ZD (informative) IEC and CENELEC code designations for flexible cords		P
1	Modification to Clause 3 .		
3.3.19	Sound exposure <i>Replace 3.3.19 of IEC 62368-1 with the following definitions:</i>		N/A
3.3.19.1	momentary exposure level, MEL metric for estimating 1 s sound exposure level from the HD 483-1 S2 test signal applied to both channels, based on EN 50332-1:2013, 4.2. Note 1 to entry: MEL is measured as A-weighted levels in dB. Note 2 to entry: See B.3 of EN 50332-3:2017 for additional information.		N/A





Attachment No.1

3.3.19.3	<p>sound exposure, E</p> <p>A-weighted sound pressure (p) squared and integrated over a stated period of time, T</p> <p>Note 1 to entry: The SI unit is Pa² s.</p> $E = \int_0^T p(t)^2 dt$		N/A
3.3.19.4	<p>sound exposure level, SEL</p> <p>logarithmic measure of sound exposure relative to a reference value, E_0, typically the 1 kHz threshold of hearing in humans.</p> <p>Note 1 to entry: SEL is measured as A-weighted levels in dB.</p> $SEL = 10 \lg \left(\frac{E}{E_0} \right) \text{ dB}$ <p>Note 2 to entry: See B.4 of EN 50332-3:2017 for additional information.</p>		N/A
3.3.19.5	<p>digital signal level relative to full scale, dBFS</p> <p>levels reported in dBFS are always r.m.s. Full scale level, 0 dBFS, is the level of a dc-free 997-Hz sine wave whose undithered positive peak value is positive digital full scale, leaving the code corresponding to negative digital full scale unused</p> <p>Note 1 to entry: It is invalid to use dBFS for non-r.m.s. levels. Because the definition of full scale is based on a sine wave, the level of signals with a crest factor lower than that of a sine wave may exceed 0 dBFS. In particular, square wave signals may reach +3,01 dBFS.</p>		N/A
2	Modification to Clause 10		
10.6	<p>Safeguards against acoustic energy sources</p> <p>Replace 10.6 of IEC 62368-1 with the following:</p>		N/A
10.6.1.1	<p>Introduction</p> <p>Safeguard requirements for protection against long-term exposure to excessive sound pressure levels from personal music players closely coupled to the ear are specified below. Requirements for earphones and headphones intended for use with personal music players are also covered. A personal music player is a portable equipment intended for use by an ordinary person, that:</p> <ul style="list-style-type: none"> – is designed to allow the user to listen to audio or audiovisual content / material; and 		N/A





Attachment No.1

	<p>– uses a listening device, such as headphones or earphones that can be worn in or on or around the ears; and</p> <p>– has a player that can be body worn (of a size suitable to be carried in a clothing pocket) and is intended for the user to walk around with while in continuous use (for example, on a street, in a subway, at an airport, etc.).</p> <p>EXAMPLES Portable CD players, MP3 audio players, mobile phones with MP3 type features, PDAs or similar equipment.</p> <p>Personal music players shall comply with the requirements of either 10.6.2 or 10.6.3.</p> <p>NOTE 1 Protection against acoustic energy sources from telecom applications is referenced to ITU-T P.360.</p> <p>NOTE 2 It is the intention of the Committee to allow the alternative methods for now, but to only use the dose measurement method as given in 10.6.5 in future. Therefore, manufacturers are encouraged to implement 10.6.5 as soon as possible.</p> <p>Listening devices sold separately shall comply with the requirements of 10.6.6. These requirements are valid for music or video mode only. The requirements do not apply to:</p> <p>– professional equipment;</p> <p>NOTE 3 Professional equipment is equipment sold through special sales channels. All products sold through normal electronics stores are considered not to be professional equipment.</p> <p>– hearing aid equipment and other devices for assistive listening;</p> <p>– the following type of analogue personal music players:</p> <ul style="list-style-type: none"> • long distance radio receiver (for example, a multiband radio receiver or world band radio receiver, an AM radio receiver), and • cassette player/recorder; <p>NOTE 4 This exemption has been allowed because this technology is falling out of use and it is expected that within a few years it will no longer exist. This exemption will not be extended to other technologies.</p> <p>– a player while connected to an external amplifier that does not allow the user to walk around</p>		
--	--	--	--





Attachment No.1

	<p>while in use.</p> <p>For equipment that is clearly designed or intended primarily for use by children, the limits of the relevant toy standards may apply.</p> <p>The relevant requirements are given in EN 71-1:2011, 4.20 and the related tests methods and measurement distances apply.</p>		
10.6.1.2	<p>Non-ionizing radiation from radio frequencies in the range 0 to 300 GHz</p> <p>The amount of non-ionizing radiation is regulated by European Council Recommendation 1999/519/EC of 12 July 1999 on the limitation of exposure of the general public to electromagnetic fields (0 Hz to 300 GHz). For intentional radiators, ICNIRP guidelines should be taken into account for Limiting Exposure to Time-Varying Electric, Magnetic, and Electromagnetic Fields (up to 300 GHz). For hand-held and body mounted devices, attention is drawn to EN 50360 and EN 50566.</p>		N/A
10.6.2	<p>Classification of devices without the capacity to estimate sound dose</p>		N/A
10.6.2.1	<p>General</p> <p>This standard is transitioning from short-term based (30 s) requirements to long-term based (40 hour) requirements. These clauses remain in effect only for devices that do not comply with sound dose estimation as stipulated in EN 50332-3.</p> <p>For classifying the acoustic output $LA_{eq,T}$, measurements are based on the A-weighted equivalent sound pressure level over a 30 s period.</p> <p>For music where the average sound pressure (long term $LA_{eq,T}$) measured over the duration of the song is lower than the average produced by the programme simulation noise, measurements may be done over the duration of the complete song. In this case, T becomes the duration of the song.</p> <p>NOTE Classical music, acoustic music and broadcast typically has an average sound pressure (long term $LA_{eq,T}$) which is much lower than the average programme simulation noise. Therefore, if the player is capable to analyse the content and compare it with the programme simulation noise, the warning does not need to be given as long as the average sound pressure of the song does not exceed the required limit.</p> <p>For example, if the player is set with the programme simulation noise to 85 dB, but the average music level of the song is only 65 dB, there is no need to give a warning or ask an</p>		N/A





Attachment No.1

	acknowledgement as long as the average sound level of the song is not above the basic limit of 85 dB.		
10.6.2.2	<p>RS1 limits (to be superseded, see 10.6.3.2)</p> <p>RS1 is a class 1 acoustic energy source that does not exceed the following:</p> <ul style="list-style-type: none"> – for equipment provided as a package (player with its listening device), and with a proprietary connector between the player and its listening device, or where the combination of player and listening device is known by other means such as setting or automatic detection, the $L_{Aeq,T}$ acoustic output shall be ≤ 85 dB when playing the fixed “programme simulation noise” described in EN 50332-1. – for equipment provided with a standardized connector (for example, a 3,5 phone jack) that allows connection to a listening device for general use, the unweighted r.m.s. output voltage shall be ≤ 27 mV (analogue interface) or -25 dBFS (digital interface) when playing the fixed “programme simulation noise” described in EN 50332-1. – The RS1 limits will be updated for all devices as per 10.6.3.2. 		N/A
10.6.2.3	<p>RS2 limits (to be superseded, see 10.6.3.3)</p> <p>RS2 is a class 2 acoustic energy source that does not exceed the following:</p> <ul style="list-style-type: none"> – for equipment provided as a package (player with its listening device), and with a proprietary connector between the player and its listening device, or when the combination of player and listening device is known by other means such as setting or automatic 130 detection, the $L_{Aeq,T}$ acoustic output shall be ≤ 100 dB(A) when playing the fixed “programme simulation noise” as described in EN 50332-1. – for equipment provided with a standardized connector (for example, a 3,5 phone jack) that allows connection to a listening device for general use, the unweighted r.m.s. output voltage shall be ≤ 150 mV (analogue interface) or -10 dBFS (digital interface) when playing the fixed “programme simulation noise” as described in EN 50332-1. 		N/A
10.6.2.4	<p>RS3 limits</p> <p>RS3 is a class 3 acoustic energy source that exceeds RS2 limits.</p>		N/A
10.6.3	Classification of devices (new)		N/A
10.6.3.1	<p>General</p> <p>Previous limits (10.6.2) created abundant false negative and false positive PMP sound level warnings. New limits, compliant with The Commission Decision of 23 June 2009, are given</p>		N/A





Attachment No.1

	below.		
10.6.3.2	<p>RS1 limits (new)</p> <p>RS1 is a class 1 acoustic energy source that does not exceed the following:</p> <ul style="list-style-type: none"> – for equipment provided as a package (player with its listening device), and with a proprietary connector between the player and its listening device, or where the combination of player and listening device is known by other means such as setting or automatic detection, the $L_{Aeq,T}$ acoustic output shall be ≤ 80 dB when playing the fixed “programme simulation noise” described in EN 50332-1. – for equipment provided with a standardized connector (for example, a 3,5 phone jack) that allows connection to a listening device for general use, the unweighted r.m.s. output voltage shall be ≤ 15 mV (analogue interface) or -30 dBFS (digital interface) when playing the fixed “programme simulation noise” described in EN 50332-1. 		N/A
10.6.3.3	<p>RS2 limits (new)</p> <p>RS2 is a class 2 acoustic energy source that does not exceed the following:</p> <ul style="list-style-type: none"> – for equipment provided as a package (player with its listening device), and with a proprietary connector between the player and its listening device, or where the combination of player and listening device is known by other means such as setting or automatic detection, the weekly sound exposure level, as described in EN 50332-3, shall be ≤ 80 dB when playing the fixed “programme simulation noise” described in EN 50332-1. – for equipment provided with a standardized connector (for example, a 3,5 phone jack) that allows connection to a listening device for general use, the unweighted r.m.s. output level, integrated over one week, as described in EN50332-3, shall be ≤ 15 mV (analogue interface) or -30 dBFS (digital interface) when playing the fixed “programme simulation noise” described in EN 50332-1. 		N/A
10.6.4	Requirements for maximum sound exposure		N/A
10.6.4.1	<p>Measurement methods</p> <p>All volume controls shall be turned to maximum during tests.</p> <p>Measurements shall be made in accordance with EN 50332-1 or EN 50332-2 as applicable.</p>		N/A
10.6.4.2	<p>Protection of persons</p> <p>Except as given below, protection requirements for parts accessible to ordinary persons, instructed persons and skilled persons are given in 4.3.</p>		N/A



Shenzhen LCS Compliance Testing Laboratory Ltd.

Add: Room 101, 201, Building A and Room 301, Building C, Juji Industrial Park, Yabianxueziwei, Shajing Street, Bao'an District, Shenzhen, Guangdong, China

Tel: +(86) 0755-82591330 | E-mail: webmaster@lcs-cert.com | Web: www.lcs-cert.com

Scan code to check authenticity



Attachment No.1

	<p>NOTE 1 Volume control is not considered a safeguard.</p> <p>Between RS2 and an ordinary person, the basic safeguard may be replaced by an instructional safeguard in accordance with Clause F.5, except that the instructional safeguard shall be placed on the equipment, or on the packaging, or in the instruction manual.</p> <p>Alternatively, the instructional safeguard may be given through the equipment display during use.</p> <p>The elements of the instructional safeguard shall be as follows:</p> <ul style="list-style-type: none"> – element 1a: the symbol , IEC 60417-6044 (2011-01) – element 2: “High sound pressure” or equivalent wording – element 3: “Hearing damage risk” or equivalent wording – element 4: “Do not listen at high volume levels for long periods.” or equivalent wording <p>An equipment safeguard shall prevent exposure of an ordinary person to an RS2 source without intentional physical action from the ordinary person and shall automatically return to an output level not exceeding what is specified for an RS1 source when the power is switched off.</p> <p>The equipment shall provide a means to actively inform the user of the increased sound level when the equipment is operated with an output exceeding RS1. Any means used shall be acknowledged by the user before activating a mode of operation which allows for an output exceeding RS1. The acknowledgement does not need to be repeated more than once every 20 h of cumulative listening time.</p> <p>NOTE 2 Examples of means include visual or audible signals. Action from the user is always needed.</p> <p>NOTE 3 The 20 h listening time is the accumulative listening time, independent of how often and how long the personal music player has been switched off.</p> <p>A skilled person shall not be unintentionally exposed to RS3.</p>		
10.6.5	Requirements for dose-based systems		N/A
10.6.5.1	<p>General requirements</p> <p>Personal music players shall give the warnings as provided below when tested according to EN</p>		N/A





Attachment No.1

	<p>50332-3, using the limits from this clause.</p> <p>The manufacturer may offer optional settings to allow the users to modify when and how they wish to receive the notifications and warnings to promote a better user experience without defeating the safeguards. This allows the users to be informed in a method that best meets their physical capabilities and device usage needs. If such optional settings are offered, an administrator (for example, parental restrictions, business/educational administrators, etc.) shall be able to lock any optional settings into a specific configuration.</p> <p>The personal music player shall be supplied with easy to understand explanation to the user of the dose management system, the risks involved, and how to use the system safely. The user shall be made aware that other sources may significantly contribute to their sound exposure, for example work, transportation, concerts, clubs, cinema, car races, etc.</p>		
<p>10.6.5.2</p>	<p>Dose-based warning and requirements</p> <p>When a dose of 100 % CSD is reached, and at least at every 100 % further increase of CSD, the device shall warn the user and require an acknowledgement. In case the user does not acknowledge, the output level shall automatically decrease to compliance with class RS1.</p> <p>The warning shall at least clearly indicate that listening above 100 % CSD leads to the risk of hearing damage or loss.</p>		<p>N/A</p>
<p>10.6.5.3</p>	<p>Exposure-based requirements</p> <p>With only dose-based requirements, cause and effect could be far separated in time, defying the purpose of educating users about safe listening practice. In addition to dose-based requirements, a PMP shall therefore also put a limit to the short-term sound level a user can listen at.</p> <p>The exposure-based limiter (EL) shall automatically reduce the sound level not to exceed 100 dB(A) or 150 mV integrated over the past 180 s, based on methodology defined in EN 50332-3.</p> <p>The EL settling time (time from starting level reduction to reaching target output) shall be 10 s or faster.</p> <p>Test of EL functionality is conducted according to EN 50332-3, using the limits from this clause. For equipment provided as a package (player with its listening device), the level integrated over 180 s shall be 100 dB or lower. For equipment provided with a standardized connector, the unweighted</p>		<p>N/A</p>





Attachment No.1

	level integrated over 180 s shall be no more than 150 mV for an analogue interface and no more than -10 dBFS for a digital interface. NOTE In case the source is known not to be music (or test signal), the EL may be disabled.		
10.6.6	Requirements for listening devices (headphones, earphones, etc.)		N/A
10.6.6.1	Corded listening devices with analogue input With 94 dB LAeq acoustic pressure output of the listening device, and with the volume and sound settings in the listening device (for example, built-in volume level control, additional sound features like equalization, etc.) set to the combination of positions that maximize the measured acoustic output, the input voltage of the listening device when playing the fixed “programme simulation noise” as described in EN 50332-1 shall be ≥ 75 mV. NOTE The values of 94 dB and 75 mV correspond with 85 dB and 27 mV or 100 dB and 150 mV.		N/A
10.6.6.2	Corded listening devices with digital input With any playing device playing the fixed “programme simulation noise” described in EN 50332-1, and with the volume and sound settings in the listening device (for example, built-in volume level control, additional sound features like equalization, etc.) set to the combination of positions that maximize the measured acoustic output, the LAeq,T acoustic output of the listening device shall be ≤ 100 dB with an input signal of -10 dBFS.		N/A
10.6.6.3	Cordless listening devices In cordless mode, – with any playing and transmitting device playing the fixed programme simulation noise described in EN 50332-1; and – respecting the cordless transmission standards, where an air interface standard exists that specifies the equivalent acoustic level; and – with volume and sound settings in the receiving device (for example, built-in volume level control, additional sound features like equalization, etc.) set to the combination of positions that maximize the measured acoustic output for the above mentioned programme simulation noise, the LAeq,T acoustic output of the listening device shall be ≤ 100 dB with an input signal of -10 dBFS.		N/A
10.6.6.4	Measurement method <i>Measurements shall be made in accordance with EN 50332-2 as applicable.</i>		N/A
3	Modification to the whole document		



Shenzhen LCS Compliance Testing Laboratory Ltd.

Add: Room 101, 201, Building A and Room 301, Building C, Juji Industrial Park, Yabianxueziwei, Shajing Street, Bao'an District, Shenzhen, Guangdong, China

Tel: +(86) 0755-82591330 | E-mail: webmaster@lcs-cert.com | Web: www.lcs-cert.com

Scan code to check authenticity





Attachment No.1

	<p>Delete all the “country” notes in the reference document according to the following list:</p> <table border="1"> <tr> <td>0.2.1</td> <td>Note 1 and 2</td> <td>1</td> <td>Note 4 and 5</td> <td>3.3.8.1</td> <td>Note 2</td> </tr> <tr> <td>3.3.8.3</td> <td>Note 1</td> <td>4.1.15</td> <td>Note</td> <td>4.7.3</td> <td>Note 1 and 2</td> </tr> <tr> <td>5.2.2.2</td> <td>Note</td> <td>5.4.2.3.2.2 Table 12</td> <td>Note c</td> <td>5.4.2.3.2.4</td> <td>Note 1 and 3</td> </tr> <tr> <td>5.4.2.3.2.4 Table 13</td> <td>Note 2</td> <td>5.4.2.5</td> <td>Note 2</td> <td>5.4.5.1</td> <td>Note</td> </tr> <tr> <td>5.4.10.2.1</td> <td>Note</td> <td>5.4.10.2.2</td> <td>Note</td> <td>5.4.10.2.3</td> <td>Note</td> </tr> <tr> <td>5.5.2.1</td> <td>Note</td> <td>5.5.6</td> <td>Note</td> <td>5.6.4.2.1</td> <td>Note 2 and 3 and 4</td> </tr> <tr> <td>5.6.8</td> <td>Note 2</td> <td>5.7.6</td> <td>Note</td> <td>5.7.7.1</td> <td>Note 1 and Note 2</td> </tr> <tr> <td>8.5.4.2.3</td> <td>Note</td> <td>10.2.1 Table 39</td> <td>Note 3 and 4 and 5</td> <td>10.5.3</td> <td>Note 2</td> </tr> <tr> <td>10.6.4</td> <td>Note 3</td> <td>F.3.3.6</td> <td>Note 3</td> <td>Y.4.1</td> <td>Note</td> </tr> <tr> <td>Y.4.5</td> <td>Note</td> <td></td> <td></td> <td></td> <td></td> </tr> </table>	0.2.1	Note 1 and 2	1	Note 4 and 5	3.3.8.1	Note 2	3.3.8.3	Note 1	4.1.15	Note	4.7.3	Note 1 and 2	5.2.2.2	Note	5.4.2.3.2.2 Table 12	Note c	5.4.2.3.2.4	Note 1 and 3	5.4.2.3.2.4 Table 13	Note 2	5.4.2.5	Note 2	5.4.5.1	Note	5.4.10.2.1	Note	5.4.10.2.2	Note	5.4.10.2.3	Note	5.5.2.1	Note	5.5.6	Note	5.6.4.2.1	Note 2 and 3 and 4	5.6.8	Note 2	5.7.6	Note	5.7.7.1	Note 1 and Note 2	8.5.4.2.3	Note	10.2.1 Table 39	Note 3 and 4 and 5	10.5.3	Note 2	10.6.4	Note 3	F.3.3.6	Note 3	Y.4.1	Note	Y.4.5	Note					N/A
0.2.1	Note 1 and 2	1	Note 4 and 5	3.3.8.1	Note 2																																																									
3.3.8.3	Note 1	4.1.15	Note	4.7.3	Note 1 and 2																																																									
5.2.2.2	Note	5.4.2.3.2.2 Table 12	Note c	5.4.2.3.2.4	Note 1 and 3																																																									
5.4.2.3.2.4 Table 13	Note 2	5.4.2.5	Note 2	5.4.5.1	Note																																																									
5.4.10.2.1	Note	5.4.10.2.2	Note	5.4.10.2.3	Note																																																									
5.5.2.1	Note	5.5.6	Note	5.6.4.2.1	Note 2 and 3 and 4																																																									
5.6.8	Note 2	5.7.6	Note	5.7.7.1	Note 1 and Note 2																																																									
8.5.4.2.3	Note	10.2.1 Table 39	Note 3 and 4 and 5	10.5.3	Note 2																																																									
10.6.4	Note 3	F.3.3.6	Note 3	Y.4.1	Note																																																									
Y.4.5	Note																																																													
4	Modification to Clause 1																																																													
1	<p>Add the following note:</p> <p><i>NOTE Z1 The use of certain substances in electrical and electronic equipment is restricted within the EU: see Directive 2011/65/EU.</i></p>	N/A																																																												
5	Modification to 4.Z1																																																													





Attachment No.1

4.Z1	<p>Add the following new subclause after 4.9:</p> <p>To protect against excessive current, short-circuits and earth faults in circuits connected to an a.c. mains, protective devices shall be included either as integral parts of the equipment or as parts of the building installation, subject to the following, a), b) and c):</p> <p>a) except as detailed in b) and c), protective devices necessary to comply with the requirements of B.3.1 and B.4 shall be included as parts of the equipment;</p> <p>b) for components in series with the mains input to the equipment such as the supply cord, appliance coupler, r.f.i. filter and switch, short-circuit and earth fault protection may be provided by protective devices in the building installation;</p> <p>c) it is permitted for pluggable equipment type B or permanently connected equipment, to rely on dedicated overcurrent and short-circuit protection in the building installation, provided that the means of protection, e.g. fuses or circuit breakers, is fully specified in the installation instructions.</p> <p>If reliance is placed on protection in the building installation, the installation instructions shall so state, except that for pluggable equipment type A the building installation shall be regarded as providing protection in accordance with the rating of the wall socket outlet.</p>		N/A
6	Modification to 5.4.2.3.2.4		
5.4.2.3.2.4	<p>Add the following to the end of this subclause:</p> <p>The requirement for interconnection with external circuit is in addition given in EN 50491-3:2009.</p>		N/A
7	Modification to 10.2.1		
10.2.1	<p>Add the following to ^{c)} and ^{d)} in table 39:</p> <p>For additional requirements, see 10.5.1.</p>		N/A
8	Modification to 10.5.1		





Attachment No.1

10.5.1	<p>Add the following after the first paragraph:</p> <p>For RS 1 compliance is checked by measurement under the following conditions:</p> <p>In addition to the normal operating conditions, all controls adjustable from the outside by hand, by any object such as a tool or a coin, and those internal adjustments or pre-sets which are not locked in a reliable manner, are adjusted so as to give maximum radiation whilst maintaining an intelligible picture for 1 h, at the end of which the measurement is made.</p> <p>NOTE Z1 Soldered joints and paint lockings are examples of adequate locking.</p> <p>The dose-rate is determined by means of a radiation monitor with an effective area of 10 cm², at any point 10 cm from the outer surface of the apparatus.</p> <p>Moreover, the measurement shall be made under fault conditions causing an increase of the high voltage, provided an intelligible picture is maintained for 1 h, at the end of which the measurement is made.</p> <p>For RS1, the dose-rate shall not exceed 1 μSv/h taking account of the background level.</p> <p>NOTE Z2 These values appear in Directive 96/29/Euratom of 13 May 1996.</p>		N/A
9	Modification to G.7.1		
G.7.1	<p>Add the following note:</p> <p>NOTE Z1 The harmonized code designations corresponding to the IEC cord types are given in Annex ZD.</p>		N/A
10	Modification to Bibliography		



Shenzhen LCS Compliance Testing Laboratory Ltd.

Add: Room 101, 201, Building A and Room 301, Building C, Juji Industrial Park, Yabianxueziwei, Shajing Street, Bao'an District, Shenzhen, Guangdong, China

Tel: +(86) 0755-82591330 | E-mail: webmaster@lcs-cert.com | Web: www.lcs-cert.com

Scan code to check authenticity



Attachment No.1

	<p>Add the following notes for the standards indicated:</p> <p>IEC 60130-9 NOTE Harmonized as EN 60130-9. IEC 60269-2 NOTE Harmonized as HD 60269-2. IEC 60309-1 NOTE Harmonized as EN 60309-1. IEC 60364 NOTE some parts harmonized in HD 384/HD 60364 series. IEC 60601-2-4 NOTE Harmonized as EN 60601-2-4. IEC 60664-5 NOTE Harmonized as EN 60664-5. IEC 61032:1997 NOTE Harmonized as EN 61032:1998 (not modified). IEC 61508-1 NOTE Harmonized as EN 61508-1. IEC 61558-2-1 NOTE Harmonized as EN 61558-2-1. IEC 61558-2-4 NOTE Harmonized as EN 61558-2-4. IEC 61558-2-6 NOTE Harmonized as EN 61558-2-6. IEC 61643-1 NOTE Harmonized as EN 61643-1. IEC 61643-21 NOTE Harmonized as EN 61643-21. IEC 61643-311 NOTE Harmonized as EN 61643-311. IEC 61643-321 NOTE Harmonized as EN 61643-321. IEC 61643-331 NOTE Harmonized as EN 61643-331.</p>	N/A
11	ADDITION OF ANNEXES	
ZB	ANNEX ZB, SPECIAL NATIONAL CONDITIONS (EN)	
4.1.15	<p>Denmark, Finland, Norway and Sweden</p> <p>To the end of the subclause the following is added: Class I pluggable equipment type A intended for connection to other equipment or a network shall, if safety relies on connection to reliable earthing or if surge suppressors are connected between the network terminals and accessible parts, have a marking stating that the equipment shall be connected to an earthed mains socket-outlet.</p> <p>The marking text in the applicable countries shall be as follows:</p> <p>In Denmark: "Apparatets stikprop skal tilsluttes en stikkontakt med jord som giver forbindelse til stikproppens jord." In Finland: "Laite on liitettävä suojakoskettimilla varustettuun pistorasiaan" In Norway: "Apparatet må tilkoples jordet stikkontakt" In Sweden: "Apparaten skall anslutas till jordat uttag"</p>	N/A



Shenzhen LCS Compliance Testing Laboratory Ltd.

Add: Room 101, 201, Building A and Room 301, Building C, Juji Industrial Park, Yabianxueziwei, Shajing Street, Bao'an District, Shenzhen, Guangdong, China

Tel: +(86) 0755-82591330 | E-mail: webmaster@lcs-cert.com | Web: www.lcs-cert.com

Scan code to check authenticity



Attachment No.1

4.7.3	<p>United Kingdom</p> <p>To the end of the subclause the following is added:</p> <p>The torque test is performed using a socket-outlet complying with BS 1363, and the plug part shall be assessed to the relevant clauses of BS 1363. Also see Annex G.4.2 of this annex</p>		N/A
5.2.2.2	<p>Denmark</p> <p>After the 2nd paragraph add the following:</p> <p>A warning (marking safeguard) for high touch current is required if the touch current exceeds the limits of 3,5 mA a.c. or 10 mA d.c.</p>		N/A
5.4.11.1 and Annex G	<p>Finland and Sweden</p> <p>To the end of the subclause the following is added:</p> <p>For separation of the telecommunication network from earth the following is applicable:</p> <p>If this insulation is solid, including insulation forming part of a component, it shall at least consist of either</p> <ul style="list-style-type: none"> • two layers of thin sheet material, each of which shall pass the electric strength test below, or • one layer having a distance through insulation of at least 0,4 mm, which shall pass the electric strength test below. <p>If this insulation forms part of a semiconductor component (e.g. an optocoupler), there is no distance through insulation requirement for the insulation consisting of an insulating compound completely filling the casing, so that clearances and creepage distances do not exist, if the component passes the electric strength test in accordance with the compliance clause below and in addition</p> <ul style="list-style-type: none"> • passes the tests and inspection criteria of 5.4.8 with an electric strength test of 1,5 kV multiplied by 1,6 (the electric strength test of 5.4.9 shall be performed using 1,5 kV), <p>and</p> <ul style="list-style-type: none"> • is subject to routine testing for electric strength during manufacturing, using a test voltage of 1,5 kV. <p>It is permitted to bridge this insulation with a capacitor complying with EN 60384-14:2005, subclass Y2.</p> <p>A capacitor classified Y3 according to EN 60384-14:2005, may bridge this insulation under</p>		N/A



Shenzhen LCS Compliance Testing Laboratory Ltd.

Add: Room 101, 201, Building A and Room 301, Building C, Juji Industrial Park, Yabianxueziwei, Shajing Street, Bao'an District, Shenzhen, Guangdong, China

Tel: +(86) 0755-82591330 | E-mail: webmaster@lcs-cert.com | Web: www.lcs-cert.com

Scan code to check authenticity



Attachment No.1

	<p>the following conditions:</p> <ul style="list-style-type: none"> the insulation requirements are satisfied by having a capacitor classified Y3 as defined by EN 60384-14, which in addition to the Y3 testing, is tested with an impulse test of 2,5 kV defined in 5.4.11; the additional testing shall be performed on all the test specimens as described in EN 60384-14; <p>the impulse test of 2,5 kV is to be performed before the endurance test in EN 60384-14, in the sequence of tests as described in EN 60384-14.</p>		
5.5.2.1	<p>Norway</p> <p>After the 3rd paragraph the following is added:</p> <p>Due to the IT power system used, capacitors are required to be rated for the applicable line-to-line voltage (230 V).</p>		N/A
5.5.6	<p>Finland, Norway and Sweden</p> <p>To the end of the subclause the following is added:</p> <p>Resistors used as basic safeguard or bridging basic insulation in class I pluggable equipment type A shall comply with G.10.1 and the test of G.10.2.</p>		N/A
5.6.1	<p>Denmark</p> <p>Add to the end of the subclause Due to many existing installations where the socket-outlets can be protected with fuses with higher rating than the rating of the socket-outlets the protection for pluggable equipment type A shall be an integral part of the equipment. <i>Justification:</i> In Denmark an existing 13 A socket outlet can be protected by a 20 A fuse.</p>		N/A
5.6.4.2.1	<p>Ireland and United Kingdom</p> <p>After the indent for pluggable equipment type A, the following is added: – the protective current rating is taken to be 13 A, this being the largest rating of fuse used in the mains plug.</p>		N/A
5.6.4.2.1	<p>France</p> <p>After the indent for pluggable equipment type A, the following is added: – in certain cases, the protective current rating of the circuit supplied from the mains is taken as 20 A instead of 16 A.</p>		N/A



Shenzhen LCS Compliance Testing Laboratory Ltd.

Add: Room 101, 201, Building A and Room 301, Building C, Juji Industrial Park, Yabianxueziwei, Shajing Street, Bao'an District, Shenzhen, Guangdong, China

Tel: +(86) 0755-82591330 | E-mail: webmaster@lcs-cert.com | Web: www.lcs-cert.com

Scan code to check authenticity



Attachment No.1

5.6.5.1	To the second paragraph the following is added: The range of conductor sizes of flexible cords to be accepted by terminals for equipment with a rated current over 10 A and up to and including 13 A is: 1,25 mm ² to 1,5 mm ² in cross-sectional area.		N/A
5.6.8	Norway To the end of the subclause the following is added: Equipment connected with an earthed mains plug is classified as class I equipment . See the Norway marking requirement in 4.1.15. The symbol IEC 60417-6092, as specified in F.3.6.2, is accepted.		N/A
5.7.6	Denmark To the end of the subclause the following is added: The installation instruction shall be affixed to the equipment if the protective conductor current exceeds the limits of 3,5 mA a.c. or 10 mA d.c.		N/A
5.7.6.2	Denmark To the end of the subclause the following is added: The warning (marking safeguard) for high touch current is required if the touch current or the protective current exceed the limits of 3,5 mA .		N/A
5.7.7.1	Norway and Sweden To the end of the subclause the following is added: The screen of the television distribution system is normally not earthed at the entrance of the building and there is normally no equipotential bonding system within the building. Therefore the protective earthing of the building installation needs to be isolated from the screen of a cable distribution system. It is however accepted to provide the insulation external to the equipment by an adapter or an interconnection cable with galvanic isolator, which may be provided by a retailer, for example. The user manual shall then have the following or similar information in Norwegian and Swedish language respectively, depending on in what country the equipment is intended to be used in: “Apparatus connected to the protective earthing of the building installation through the mains connection or through other apparatus with a connection to protective earthing – and to a television distribution system using coaxial cable, may in some circumstances create a fire hazard. Connection to a television distribution system therefore has to be provided through a device providing electrical isolation below a certain frequency range (galvanic isolator, see EN 60728-11)”		N/A



Shenzhen LCS Compliance Testing Laboratory Ltd.

Add: Room 101, 201, Building A and Room 301, Building C, Juji Industrial Park, Yabianxueziwei, Shajing Street, Bao'an District, Shenzhen, Guangdong, China

Tel: +(86) 0755-82591330 | E-mail: webmaster@lcs-cert.com | Web: www.lcs-cert.com

Scan code to check authenticity



Attachment No.1

	<p>NOTE In Norway, due to regulation for CATV-installations, and in Sweden, a galvanic isolator shall provide electrical insulation below 5 MHz. The insulation shall withstand a dielectric strength of 1,5 kV r.m.s., 50 Hz or 60 Hz, for 1 min.</p> <p>Translation to Norwegian (the Swedish text will also be accepted in Norway):</p> <p>“Apparater som er koplet til beskyttelsesjord via nettplugg og/eller via annet jordtilkoplet utstyr – og er tilkoplet et koaksialbasert kabel-TV nett, kan forårsake brannfare. For å unngå dette skal det ved tilkopling av apparater til kabel-TV nett installeres en galvanisk isolator mellom apparatet og kabel-TV nettet.”</p> <p>Translation to Swedish: ”Apparater som är kopplad till skyddsjord via jordat vägguttag och/eller via annan utrustning och samtidigt är kopplad till kabel-TV nät kan i vissa fall medföra risk för brand. För att undvika detta skall vid anslutning av apparaten till kabel-TV nät galvanisk isolator finnas mellan apparaten och kabel-TV nätet.”</p>		
8.5.4.2.3	<p>United Kingdom</p> <p>Add the following after the 2nd dash bullet in 3rd paragraph:</p> <p>An emergency stop system complying with the requirements of IEC 60204-1 and ISO 13850 is required where there is a risk of personal injury.</p>		N/A
B.3.1 and B.4	<p>Ireland and United Kingdom</p> <p>The following is applicable:</p> <p>To protect against excessive currents and short-circuits in the primary circuit of direct plug-in equipment, tests according to Annexes B.3.1 and B.4 shall be conducted using an external miniature circuit breaker complying with EN 60898-1, Type B, rated 32A. If the equipment does not pass these tests, suitable protective devices shall be included as an integral part of the direct plug-in equipment, until the requirements of Annexes B.3.1 and B.4 are met</p>		N/A
G.4.2	<p>Denmark</p> <p>To the end of the subclause the following is added:</p> <p>Supply cords of single phase appliances having a rated current not exceeding 13 A shall be provided with a plug according to DS 60884-2-D1:2011.</p> <p>CLASS I EQUIPMENT provided with socket-outlets</p>		N/A



Shenzhen LCS Compliance Testing Laboratory Ltd.

Add: Room 101, 201, Building A and Room 301, Building C, Juji Industrial Park, Yabianxueziwei, Shajing Street, Bao'an District, Shenzhen, Guangdong, China

Tel: +(86) 0755-82591330 | E-mail: webmaster@lcs-cert.com | Web: www.lcs-cert.com

Scan code to check authenticity



Attachment No.1

	<p>with earth contacts or which are intended to be used in locations where protection against indirect contact is required according to the wiring rules shall be provided with a plug in accordance with standard sheet DK 2-1a or DK 2-5a.</p> <p>If a single-phase equipment having a RATED CURRENT exceeding 13 A or if a polyphase equipment is provided with a supply cord with a plug, this plug shall be in accordance with the standard sheets DK 6-1a in DS 60884-2-D1 or EN 60309-2.</p> <p>Mains socket outlets intended for providing power to Class II apparatus with a rated current of 2,5 A shall be in accordance DS 60884-2-D1:2011 standard sheet DKA 1-4a.</p> <p>Other current rating socket outlets shall be in compliance with Standard Sheet DKA 1-3a or DKA 1-1c.</p> <p>Mains socket-outlets with earth shall be in compliance with DS 60884-2-D1:2011 Standard Sheet DK 1-3a, DK 1-1c, DK1-1d, DK 1-5a or DK 1-7a</p> <p><i>Justification:</i> Heavy Current Regulations, Section 6c</p>		
G.4.2	<p>United Kingdom</p> <p>To the end of the subclause the following is added:</p> <p>The plug part of direct plug-in equipment shall be assessed to BS 1363: Part 1, 12.1, 12.2, 12.3, 12.9, 12.11, 12.12, 12.13, 12.16, and 12.17, except that the test of 12.17 is performed at not less than 125 °C. Where the metal earth pin is replaced by an Insulated Shutter Opening Device (ISOD), the requirements of clauses 22.2 and 23 also apply.</p>		N/A
G.7.1	<p>United Kingdom</p> <p>To the first paragraph the following is added:</p> <p>Equipment which is fitted with a flexible cable or cord and is designed to be connected to a mains socket conforming to BS 1363 by means of that flexible cable or cord shall be fitted with a 'standard plug' in accordance with the Plugs and Sockets etc. (Safety) Regulations 1994, Statutory Instrument 1994 No. 1768, unless exempted by those regulations.</p> <p>NOTE "Standard plug" is defined in SI 1768:1994 and essentially means an approved plug conforming to BS 1363 or an approved conversion plug.</p>		N/A





Attachment No.1

G.7.1	<p>Ireland</p> <p>To the first paragraph the following is added:</p> <p>Apparatus which is fitted with a flexible cable or cord shall be provided with a plug in accordance with Statutory Instrument 525: 1997, "13 A Plugs and Conversion Adapters for Domestic Use Regulations: 1997. S.I. 525 provides for the recognition of a standard of another Member State which is equivalent to the relevant Irish Standard</p>		N/A
G.7.2	<p>Ireland and United Kingdom</p> <p>To the first paragraph the following is added:</p> <p>A power supply cord with a conductor of 1,25 mm² is allowed for equipment which is rated over 10 A and up to and including 13 A.</p>		N/A
ZC	ANNEX ZC, NATIONAL DEVIATIONS (EN)		
10.5.2	<p>Germany</p> <p>The following requirement applies:</p> <p>For the operation of any cathode ray tube intended for the display of visual images operating at an acceleration voltage exceeding 40 kV, authorization is required, or application of type approval (Bauartzulassung) and marking.</p> <p><i>Justification:</i> German ministerial decree against ionizing radiation (Röntgenverordnung), in force since 2002-07-01, implementing the European Directive 96/29/EURATOM.</p> <p>NOTE Contact address: Physikalisch-Technische Bundesanstalt, Bundesallee 100, D-38116 Braunschweig, Tel.: Int+49-531-592-6320, Internet: http://www.ptb.de</p>		N/A



Shenzhen LCS Compliance Testing Laboratory Ltd.

Add: Room 101, 201, Building A and Room 301, Building C, Juji Industrial Park, Yabianxueziwei, Shajing Street, Bao'an District, Shenzhen, Guangdong, China

Tel: +(86) 0755-82591330 | E-mail: webmaster@lcs-cert.com | Web: www.lcs-cert.com

Scan code to check authenticity



ZD	IEC and CENELEC CODE DESIGNATIONS FOR FLEXIBLE CORDS (EN)		N/A	
	Type of flexible cord	Code designations		
		IEC		CENELEC
PVC insulated cords				
Flat twin tinsel cord	60227 IEC 41	H03VH-Y		
Light polyvinyl chloride sheathed flexible cord	60227 IEC 52	H03VV-F H03VVH2-F		
Ordinary polyvinyl chloride sheathed flexible cord	60227 IEC 53	H05VV-F H05VVH2-F		
Rubber insulated cords				
Braided cord	60245 IEC 51	H03RT-F		
Ordinary tough rubber sheathed flexible cord	60245 IEC 53	H05RR-F		
Ordinary polychloroprene sheathed flexible cord	60245 IEC 57	H05RN-F		
Heavy polychloroprene sheathed flexible cord	60245 IEC 66	H07RN-F		
Cords having high flexibility				
Rubber insulated and sheathed cord	60245 IEC 86	H03RR-H		
Rubber insulated, crosslinked PVC sheathed cord	60245 IEC 87	H03RV4-H		
Crosslinked PVC insulated and sheathed cord	60245 IEC 88	H03V4V4-H		
Cords insulated and sheathed with halogen-free thermoplastic compounds				
Light halogen-free thermoplastic insulated and sheathed flexible cords		H03Z1Z1-F H03Z1Z1H2-F		
Ordinary halogen-free thermoplastic insulated and sheathed flexible cords		H05Z1Z1-F H05Z1Z1H2-F		



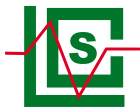

Attachment No.2

BS 1363-1: 2016+A1 (Partial)

Clause	Requirement - Test	Result – Remark	Verdict
12	Construction of Plugs		P
12.1	The disposition of the pins shall be shown as figure 4.	The dispositions of the pins were shown as specified.	P
12.2	Pin and sleeve dimensions, body outline were checked according to figure 4 of BS1363: part 1.	The outline of the plug did not exceed the specified dimensions at a distance of 6.76mm from the engagement surface. (limit: >6.35mm) The measured dimensions of item shown in fig. 4 were found within the specified limits.	P
	The plug portion should enter the gauge fully with a force less than 10N was applied to the centre of the sample at right angle.	Sample was entered into the gauge completely.	P
12.3	No part of a line or neutral pin shall be less than 9,5mm from the periphery of the plug measured along the engagement surface.	9.76mm	P
12.9	Plug pins were constructed of brass	Complied.	P
12.9.1	Exposed surface of plug pins were smooth and free from burrs or sharp edges and other irregularities, which could cause damage or excessive wear to sockets or shutters.	Complied.	P
12.9.4	The adaptor plug pins were tested as specified in the standard.	Complied. After being subjected to a force of 1100N for L, N pin, 400N for ISOD pin, the pin portion could fit the relevant gauge.	P
12.9.6	Each pin of the adaptor was subjected to a torque of 1Nm for 60s as specified in the standard.	Complied. After the test, the pin portion could fit the relevant gauge.	P
12.11	The adaptors were tested as specified in the standard. After being placed in an oven at 70°C for 1 hour, each pin of the samples was subjected for 60 sec. to a pull of 100N in the oven.	Complied. After the above test, no plug pin was detached and the plug pins could fit the relevant gauge.	P
12.12	The degree of flexibility of mounting of the plug pins was checked according to 12.12.1	Measured value: Max. 1° 12' (test on each sources of material, max. value measured) (limit Max. 3° 30').	P
12.16	Line and neutral plug pin shall be fitted with insulating sleeves. The dimensions of the pin and sleeve shall fall within the specific limit.	Complied. Both line and neutral pins were fitted with insulating sleeves.	P
12.17.1	Plug pin sleeve shall be compliance with 12.17.2 to 12.17.4	Complied.	P
12.17.2	Electric strength test applied between the metal part of plug pin and the sleeve (1250±30V)	Complied. No breakdown or flashover occurs.	P



Shenzhen LCS Compliance Testing Laboratory Ltd.

Add: Room 101, 201, Building A and Room 301, Building C, Juji Industrial Park, Yabianxueziwei, Shajing Street, Bao'an District, Shenzhen, Guangdong, China

Tel: +(86) 0755-82591330 | E-mail: webmaster@lcs-cert.com | Web: www.lcs-cert.com

Scan code to check authenticity

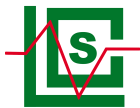

Attachment No.2

BS 1363-1: 2016+A1 (Partial)			
Clause	Requirement - Test	Result – Remark	Verdict
12.17.3	Abrasion test for plug pin sleeve The plug pin sleeves were subjected to 20000 movements of abrasion as specified in the standard.	Complied. After the test, the sleeves showed no damage that impaired further use and could satisfy the electric strength test in 12.17. 2	P
12.17.4	The plug pins with sleeves were placed in a heating cabinet at 200°C and tested according to the standard for 120min. Arrange the test as Figure 10 of BS 1363-1.	After the test, the thickness of sleeves of plug pins (Line and neutral pins) remaining at the impression point reduced by max. 20%	P
22.2	Parts of insulating material shall be sufficiently resistant to heat and still shaving its location and function.	Complied. See 22.2.1	P
22.2.1	Compliance checked as follows: a) Parts of ceramic material are used; b) external parts of plugs tested according to 22.1.3; c) all other parts of insulating material including ISOD subjected to the ball pressure at a temperature of 75°C ± 5°C	See appended table 22.2.1	P
23	Resistance to abnormal heat, fire and tracking		P
23.1	Plugs shall be proof against abnormal heat, fire and tracking		P
23.1.1	Compliance shall be checked by the test described in 23.2		P
23.2	Glow-wire test The test is performed according to BS EN 60695-2-11:2014 and at the test temperature given in Table 10 a) Parts necessary to retain live parts in position including ISOD were tested at 750°C. b) Parts not necessary to retain live in position were tested at 650°C.	See appended table 23.2	P
Additional requirement for the solid insulated shutter opening device (ISOD) according to BS1363-1			
12.2	Plug fitted with an ISOD shall comply with all the dimensions specified in Fig. 4a with exception of the width of the ISOD, which should be 4,05mm max. and 3,90mm min. and its height which should be 8,05mm max. and 7,75mm min.	See measured dimensions in Table 3	P
12.9.4	Solid insulated opening device were tested as specified in the standard.	After being subjected to a forced of 400N, the pin could fit the relevant gauge.	P



**Attachment No.2****BS 1363-1: 2016+A1 (Partial)**

Clause	Requirement - Test	Result – Remark	Verdict
12.9.5	<p>Plugs with ISOD shall not cause excessive wear to socket contacts or shutters of sockets-outlets</p> <p>The test use a separate sample of plug with ISOD for each type of socket-outlet, with each sample being inserted into and withdrawn from the socket-outlet at a rate of 6 insertions and 6 withdrawals per minute, the speed of travel of the plug being approximately 150mm/s</p>	<p>After 5000 insertions and withdrawals completed, socket outlets show no damage that would impair further use.</p> <p>Plugs show no damage and suit for the dimensional requirements according to clause 12.2.</p> <p>The shutters of the socket-outlets operate satisfactorily and socket contacts safety shielded. (test on each sources of material)</p>	P
12.9.6	ISOD of the adapter was subjected to a torque of 1Nm for 60s as specified in the standard.	After the test, the pin portion could fit the relevant gauge.	P

Additional consideration for the special snap-in construction.

20.1.3	<p>Plugs are tested in the tumbling barrel.</p> <p>a) rewirable plugs marked BS 1363: 1000 falls</p> <p>b) non-rewirable plugs marked BS 1363: 2500 falls</p> <p>c) plugs marked BS 1363/A: 5000 falls</p> <p>d) plugs marked BS 1363/EV: 5000 falls</p>	For plug portion	P
--------	--	------------------	---



Shenzhen LCS Compliance Testing Laboratory Ltd.

Add: Room 101, 201, Building A and Room 301, Building C, Juji Industrial Park, Yabianxueziwei, Shajing Street, Bao'an District, Shenzhen, Guangdong, China

Tel: +(86) 0755-82591330 | E-mail: webmaster@lcs-cert.com | Web: www.lcs-cert.com

Scan code to check authenticity



BS 1363-1: 2016+A1 (Partial)

Clause	Requirement - Test	Result – Remark	Verdict
--------	--------------------	-----------------	---------

22.2.1 TABLE: Ball-pressure test							
Specimen				Ball-pressure test			
Part	Material	Material-thickness [mm]	Colour	[C°]	Measured [mm]	Required [mm]	Result
Plug portion (including ISOD)	Sabic Innovative Plastics US L L C / EXL9330(GG)(X)(f1)(B1)(IP)	--	--	125	0.91	< 2.0	Pass
Plug portion (including ISOD)	Sabic Innovative Plastics US L L C/940(f1)	--	--	125	0.91	< 2.0	Pass
pin sleeving	Sabic Innovative Plastics US L L C / EXL9330(GG)(X)(f1)(B1)(IP)	--	--	125	0.91	< 2.0	Pass
pin sleeving	Sabic Innovative Plastics US L L C/940(f1)	--	--	125	0.91	< 2.0	Pass
Supplementary information:							



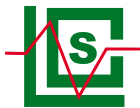

BS 1363-1: 2016+A1 (Partial)

Clause	Requirement - Test	Result – Remark	Verdict
--------	--------------------	-----------------	---------

Part	Specimen			Flame					
	Material	Material-thickness [mm]	Colour	[°C]	Start [s]	End [s]	Height [mm]	Ignition of tissue paper	Result
Enclosure	Sabic Innovative Plastics US L L C / EXL9330(GG)(X)(f1)(B1)(IP)	--	--	750	--	--	--	No	Pass
Enclosure	Sabic Innovative Plastics US L L C/940(f1)	--	--	750	--	--	--	No	Pass
Plug portion (including ISOD)	Sabic Innovative Plastics US L L C / EXL9330(GG)(X)(f1)(B1)(IP)	--	--	750	--	--	--	No	Pass
Plug portion (including ISOD)	Sabic Innovative Plastics US L L C/940(f1)	--	--	750	--	--	--	No	Pass

Supplementary information:





BS 1363-1: 2016+A1 (Partial)

Clause	Requirement - Test	Result - Remark	Verdict
--------	--------------------	-----------------	---------

Interchangeable UK plug portion for switching power adapter

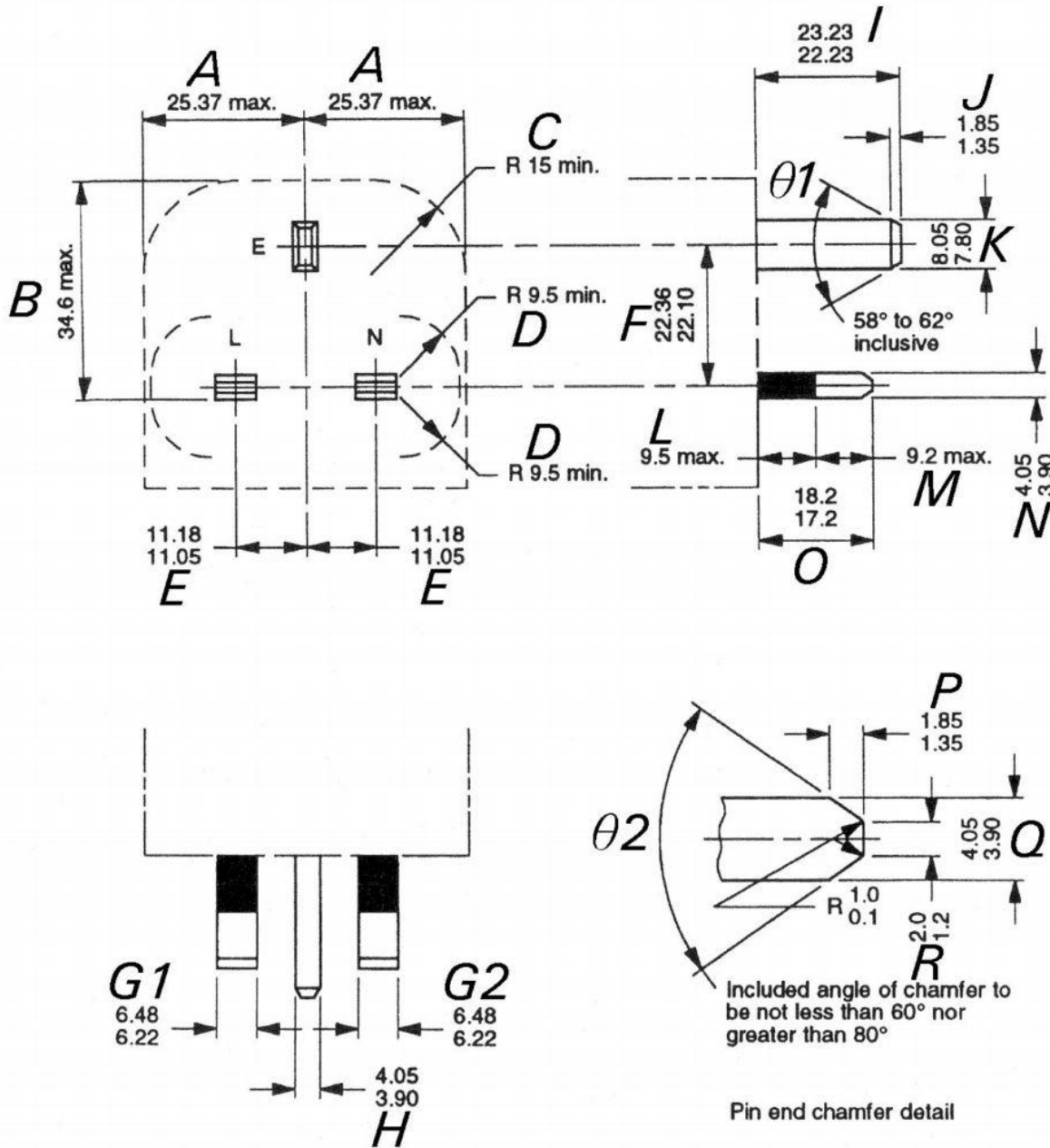



Attachment No.2

BS 1363-1: 2016+A1 (Partial)

Clause	Requirement - Test	Result – Remark	Verdict
--------	--------------------	-----------------	---------

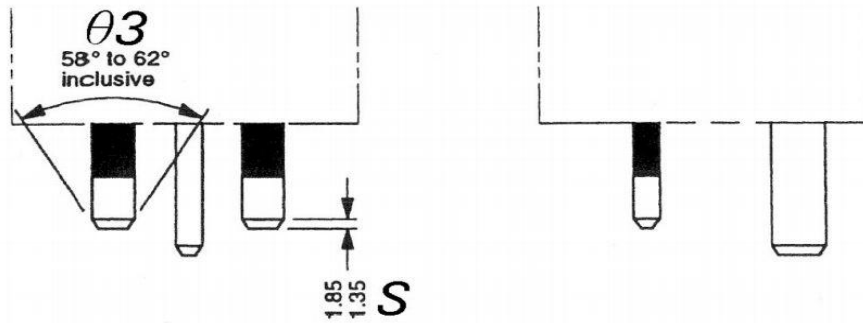

Permitted additional chamfers on L and N pins
 (if additional chamfer is used it has to be on both pins)

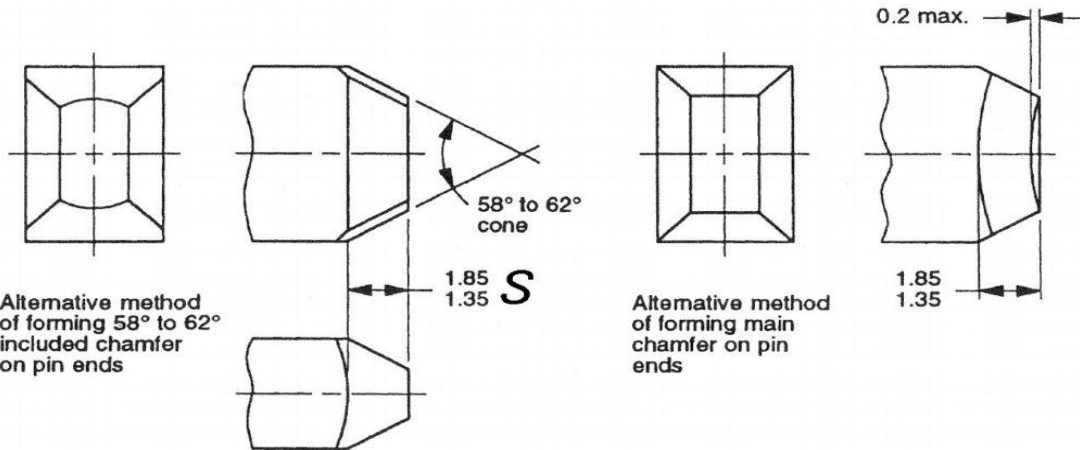

All dimensions are in millimetres.

NOTE 1. External edges of pins are to be free from burrs or sharp edges and may have a radius not exceeding 1 mm.

NOTE 2. The surfaces of pins are to be flat within the specified tolerances.



Shenzhen LCS Compliance Testing Laboratory Ltd.

Add: Room 101, 201, Building A and Room 301, Building C, Juji Industrial Park, Yabianxueziwei, Shajing Street, Bao'an District, Shenzhen, Guangdong, China

Tel: +(86) 0755-82591330 | E-mail: webmaster@lcs-cert.com | Web: www.lcs-cert.com

Scan code to check authenticity



BS 1363-1: 2016+A1 (Partial)

Clause	Requirement - Test	Result – Remark	Verdict
--------	--------------------	-----------------	---------

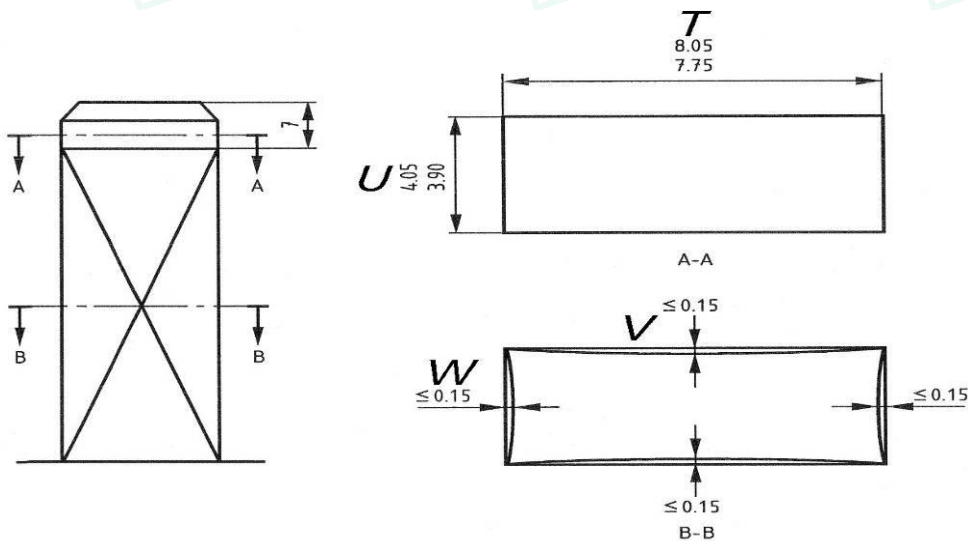

Solid insulated shutter opening device (ISOD)

NOTE Section A-A to be measured away from chamfer as shown.

Appendix 1 (Refer to 12.2)



Shenzhen LCS Compliance Testing Laboratory Ltd.
 Add: Room 101, 201, Building A and Room 301, Building C, Juji Industrial Park, Yabianxueziwei, Shajing Street, Bao'an District, Shenzhen, Guangdong, China
 Tel: +(86) 0755-82591330 | E-mail: webmaster@lcs-cert.com | Web: www.lcs-cert.com
 Scan code to check authenticity

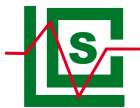

BS 1363-1: 2016+A1 (Partial)

Clause	Requirement - Test	Result – Remark	Verdict
--------	--------------------	-----------------	---------

13A Plug Portion Dimensions

<u>Linear Dimensions (mm)</u>	<u>Measurement (sample A)</u>	<u>Measurement (sample B)</u>	<u>Measurement (sample C)</u>	<u>Limit</u>	<u>Verdict</u>
-------------------------------	-------------------------------	-------------------------------	-------------------------------	--------------	----------------

For models:

A	23.96	24.00	23.98	25.37 max.	P
B	33.14	33.15	33.10	34.6 max.	P
C	15.86	15.69	15.70	15 min.	P
D	9.80	9.76	9.78	9.5 min.	P
E (from L to E)	11.11	11.12	11.11	11.05 - 11.18	P
(from N to E)	11.11	11.12	11.11		P
F	22.33	22.30	22.30	22.10 - 22.36	P
G1	6.31	6.30	6.30	6.22 – 6.48	P
G2	6.31	6.30	6.30	6.22 – 6.48	P
H	4.00	3.99	4.01	3.90 – 4.05	P
I	22.96	22.97	22.98	22.23 – 23.23	P
J	1.48	1.43	1.42	1.35 – 1.85	P
K	7.84	7.85	7.86	7.80 - 8.05	P
L (line)	9.07	9.08	9.10	9.5 max.	P
(neutral)	9.07	9.08	9.10		P
M (line)	8.61	8.60	8.60	9.2 max.	P
(neutral)	8.61	8.60	8.60		P
N (line) (sleeve)	3.99	3.98	3.97	3.90 – 4.05	P
(neutral) (sleeve)	3.99	3.98	3.97		P
O (line)	18.01	18.03	18.00	17.20 – 18.20	P
(neutral)	18.01	18.03	18.00		P
P (line)	1.42	1.44	1.45	1.35 – 1.85	P
(neutral)	1.42	1.44	1.45		P



Shenzhen LCS Compliance Testing Laboratory Ltd.

Add: Room 101, 201, Building A and Room 301, Building C, Juji Industrial Park, Yabianxueziwei, Shajing Street, Bao'an District, Shenzhen, Guangdong, China

Tel: +(86) 0755-82591330 | E-mail: webmaster@lcs-cert.com | Web: www.lcs-cert.com

Scan code to check authenticity



BS 1363-1: 2016+A1 (Partial)

Clause	Requirement - Test	Result – Remark	Verdict	
(earth)	1.44	1.45	P	
Q (line) (metal)	3.98	3.97	3.90 – 4.05	
(neutral) (metal)	3.98	3.99		
(earth) (metal)	3.94	3.95		
R (line)	1.63	1.62	1.2 – 2.0	
(neutral)	1.62	1.62		
(earth)	1.63	1.63		
S (line/ neutral)	1.64	1.64	1.35 – 1.85	P
θ1	61	61	58° – 62°	P
θ2 (line/ neutral)	65	64	60° – 80°	P
(earth)	65	66		P
θ3	60	60	58° – 62°	P

¹⁾The outline of the plug is different from shown in figure, but it can insert the gauge fully with a force less than 10 N. So the dimension C is not applicable for the case.

For solid insulated shutter opening device

<u>Linear Dimensions (mm)</u>	<u>Measurement (sample A)</u>	<u>Measurement (sample B)</u>	<u>Measurement (sample C)</u>	<u>Limit</u>	<u>Verdict</u>
T	7.88	7.89	7.90	7.75 – 8.05	P
U	3.97	3.98	3.99	3.90 – 4.05	P
V (E → L)	0.03	0.03	0.02	0.15 max.	P
(E → N)	0.03	0.03	0.02	0.15 max.	P
W (E → Top)	0.02	0.03	0.03	0.15 max.	P
(E → L&N)	0.02	0.02	0.02	0.15 max.	P





Details of: External view



Details of: External view





Details of: External view



Details of: External view





Details of: Internal view



Details of: PCB view

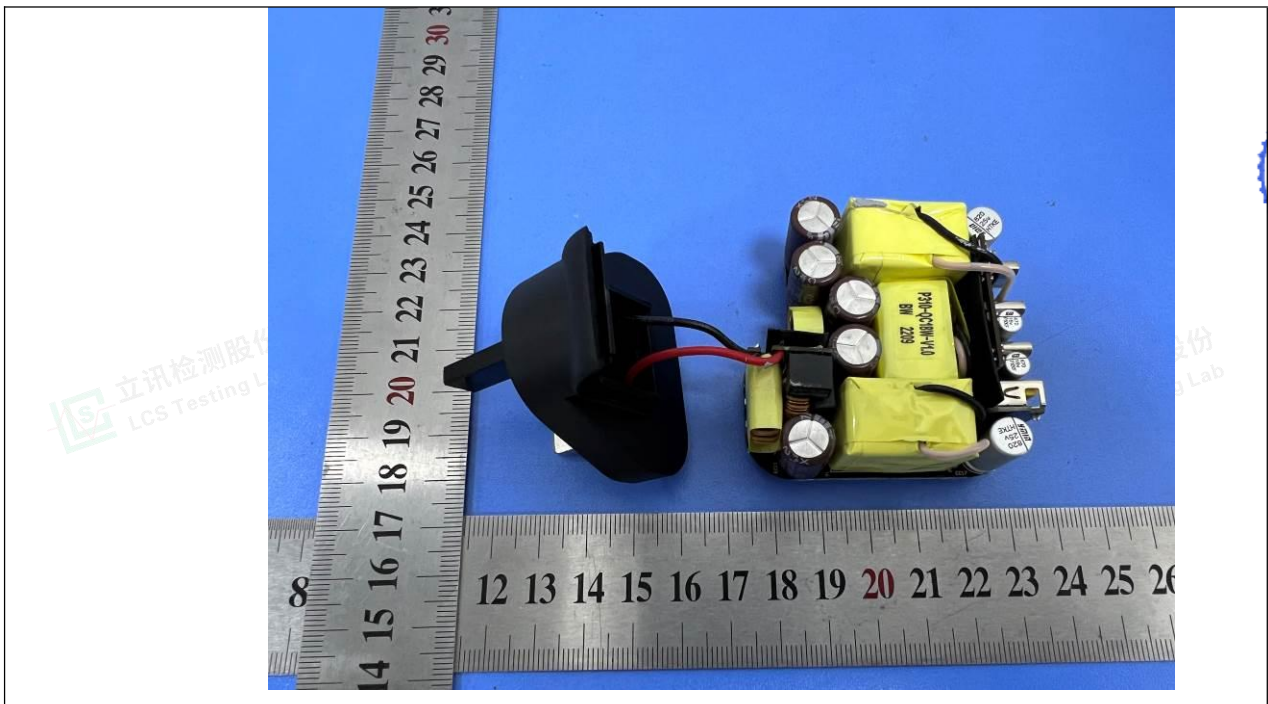



Details of: PCB view

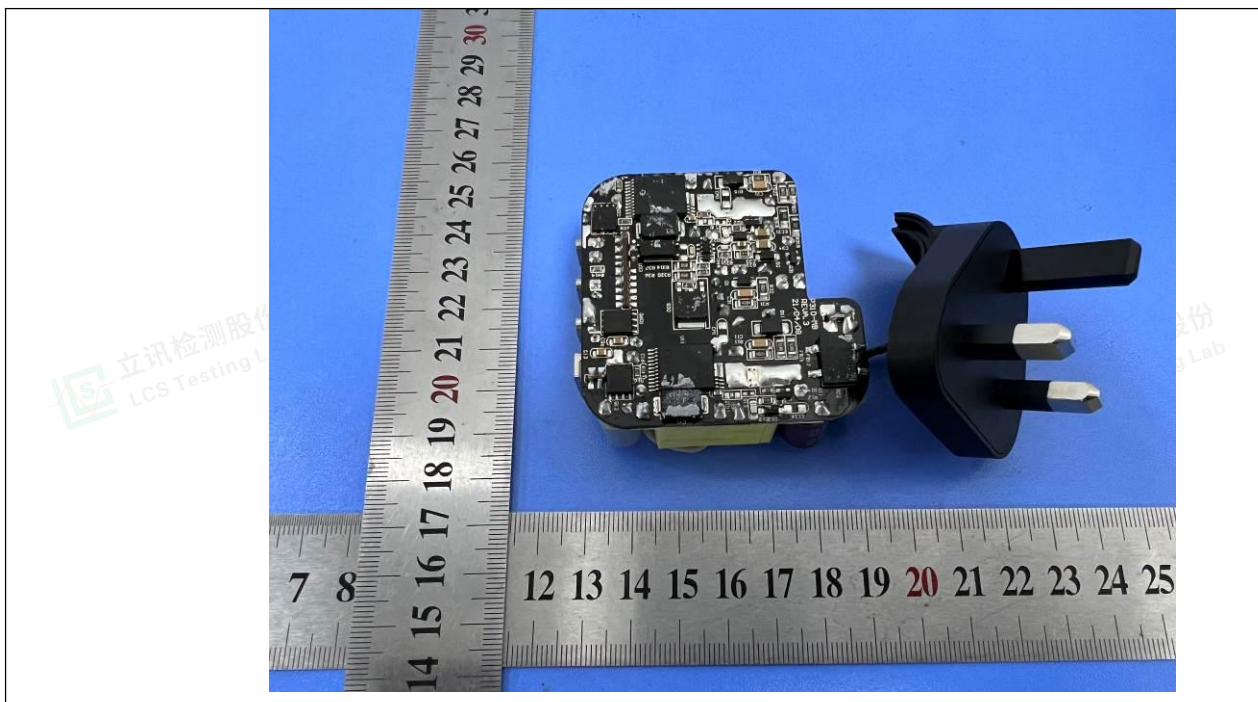

---End of Test report---

